

Project: FIRE SAFE TEST FOR VALVES

Certificate No.: 370/09 - 9587

Client: J.C FABRICA DE VALVULAS, S.A.

Office: Sant Joan Despí (BCN)

Client's Order No.: ---

Date: 22.04.09

Inspection dates

First: 22.04.09

Order Status: Complete

Final: 22.04.09

This certificate is issued to

Messrs. **J.C FABRICA DE VALVULAS, S.A.**, upon their request that the undersigned Suveryor to this Society did attend their premises at their works in Sant Boi de Llobregat - Barcelona (Spain) for the purpose of witnessing the FIRE SAFE TEST in accordance with the requirements specified in ISO 10497:2004, on the following type of valve:

A manually operate Gate Valve of 8" bore 8", as per fig. VC150BB, 150#
Body and Bonnet material A216 Gr.WCB
Trim: SEE DRAWING GGC-060409

Marks:

- BODY : Col. Z5507
- BONNET : Col. Z5485

The test conducted on the valve previously subject to hydraulic pressure was as follows:

The valve in the closed position, filled with water under test pressure, was put in a box and exposed to flames with an environmental temperature in the region 750° C for a period of 30 minutes and established the leakage trough the seat and external to atmosphere during this period. The temperature was checked and recorded every two minutes, while leakages were determined using containers collecting the water leaked during burn period. Afterwards cool-down to 100° C. The valve seat and external hydrostatically tested to the appropriate test pressure and leakages recorded accordingly. Subsequently manually opened up under test pressure differential and finally the valve was fully hydrottested and leakages recorded.

All the following values were determined and recorded together with temperatures, times and pressures as shown on manufacturers Fire Safe Test Report n° C370/09

SGS Tecnos, S.A.

1. Through-valve leakage during burn period - SATISFACTORY.
2. External leakage during burn and cool-down period - SATISFACTORY.
3. Through-valve leakage during operational test - SATISFACTORY.
4. External leakage during operational test - SATISFACTORY.
5. Operability to full open position and external leakage - SATISFACTORY.

The valve was subject to a visual examination with satisfactory results and subsequently dismantled in order to verify that valves components comply with the drawing and parts list supplied by the manufacturer, while seat rings were found completely destroyed.

The manufacturers Fire Safe Test Report nº C370/09 and drawing GGC-60409 herewith attached were satisfactory checked and signed.

The above is considered in accordance with the mentioned specifications requirements, therefore the subject valve has satisfactory passed the prescribed fire test and can be also qualified as follows.

<u>DN</u>	<u>CLASS RATING</u>	<u>PN RATING</u>
200 and larger	150#, 300#	10, 16, 25, 40



SGS Tecnos, S.A.
C/ Les Planes nº 1, Nave B
Polígon Industrial Fontserre
08948 Sant Joan Despí (Barcelona)
Tel.: (34) 93 477 01 71 - 93 477 01 69
Fax.: (34) 93 373 15 00

Surveyor Javier Aranda García

DOCUMENTS ATTACHED:
Sheets reviewed and stamped
Accordingly.

GGC-60409

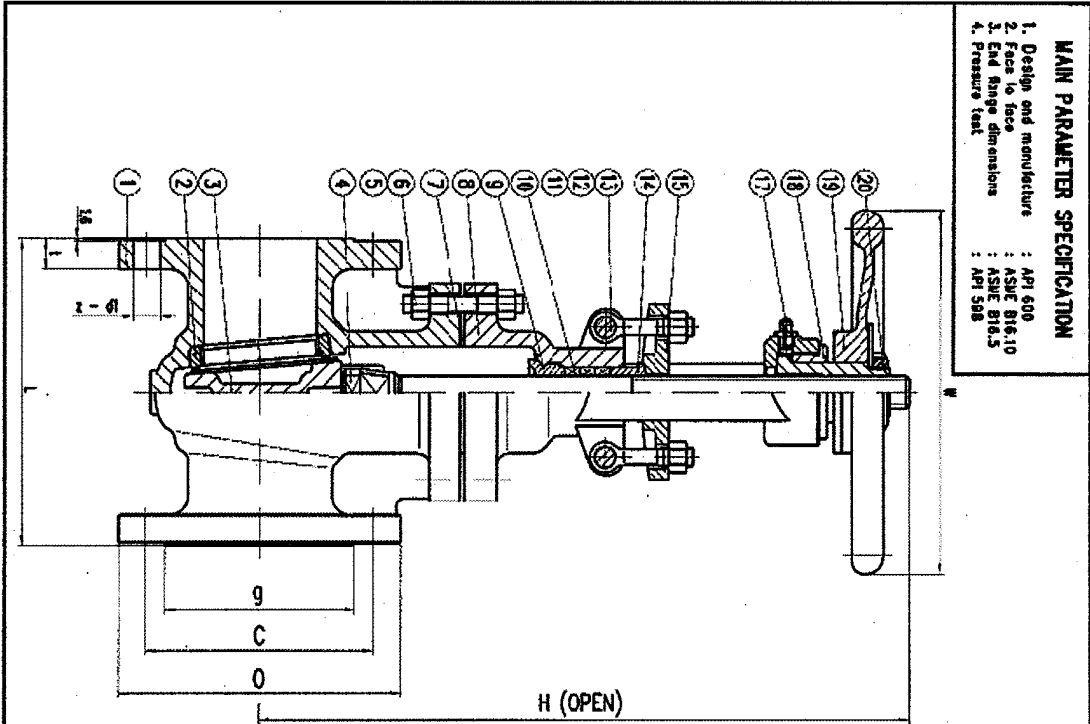

ITEM	Identification Number	NPS		L	H	W	O	C	g	f	z - d1
		10	12								
251	GN-15V-4145	3"	3"	203	512	250	190	151.5	221	19	4 - 619
259	GN-15V-4147	3"	3"	203	512	250	190	151.5	221	19	4 - 619
268	GN-15V-1171	4"	4"	229	595	229	229	191.5	251	24	8 - 619
256	GN-15V-4143	8"	8"	206	292	350	343	298.5	210	26	8 - 672
258	GN-15V-4148	8"	8"	200	292	350	343	298.5	210	26	8 - 672

POS.	QUAN.	DESCRIPTON	MATERIAL	DRAWING N°
20	1	4 X LOCK NUT	CHROME SI	
19	1	WASHER	CHROME SI	
18	1	RETAINING NUT	CHROME SI	
17	1	OH DUB	CHROME SI	
16	1	STW NUT	A 491 Q 102	
15	1	FLANG FLANGE	A 205 Q 102	
14	1	FLANG FLANGE	A 132 F8	
13	1	FLANG FLANGE	A 133 B7	
12	1	STW PACKING	CHROME SI	
11	1	STW NUT	A 14 24	
10	1	BACKSET BUSHING	SECCONITE & CL	
9	1	BRONZ	A 705 Q 102	
8	1	BRONZ	S 5304 - CRAPHITE	
7	1	BRONZ NUT	A 134 24	
6	1	BRONZ NUT	A 134 24	
5	1	BRONZ NUT	A 134 24	
4	1	BRONZ NUT	A 134 24	
3	1	WASHER	A 705 Q 102 & SECCO	
2	1	SECCO RING	A 132 F8	
1	1	BOIT	A 705 Q 102	

Revis. 0: 2nd issue

Dimensions: 3"-09'-08" 41x

Weight: 2.100 kg

Substance: Steel

Substitutes by:

GENERAL ASSEMBLY DRAWING
 GATE VALVE DMS 150

JC Valves

Fabrica de valvules, s.a.
 Tel: +34 934 80 81 70 Fax: +34 934 80 81 80
 www.valves@jcvalves.com

Drawing n°: GGC-60409

Scale: 1:1

DATE: 22.04.09

APPROV:

Project: FIRE SAFE TEST FOR VALVES

Certificate No.: 359/09 - 9587

Client: J.C FABRICA DE VALVULAS, S.A.

Office: Sant Joan Despí (BCN)

Client's Order No.: ---

Date: 17.04.09

Inspection dates

First: 17.04.09

Order Status: Complete

Final: 17.04.09

This certificate is issued to

Messrs. **J.C FABRICA DE VALVULAS, S.A.**, upon their request that the undersigned Suveyor to this Society did attend their premises at their works in Sant Boi de Llobregat - Barcelona (Spain) for the purpose of witnessing the FIRE SAFE TEST in accordance with the requirements specified in ISO 10497:2004, on the following type of valve:

A manually operate Gate Valve of 3" bore 3", as per fig. VC150BB, 150#
Body and Bonnet material A216 Gr.WCB
Trim: SEE DRAWING GGC-01151

Marks:

- BODY : Col. Z5482
- BONNET : Col. Z5488

The test conducted on the valve previously subject to hydraulic pressure was as follows:

The valve in the closed position, filled with water under test pressure, was put in a box and exposed to flames with an environmental temperature in the region 750° C for a period of 30 minutes and established the leakage trough the seat and external to atmosphere during this period. The temperature was checked and recorded every two minutes, while leakages were determined using containers collecting the water leaked during burn period. Afterwards cool-down to 100° C. The valve seat and external hydrostatically tested to the appropriate test pressure and leakages recorded accordingly. Subsequently manually opened up under test pressure differential and finally the valve was fully hydrottested and leakages recorded.

All the following values were determined and recorded together with temperatures, times and pressures as shown on manufacturers Fire Safe Test Report n° C359/09

SGS Tecnos, S.A.

1. Through-valve leakage during burn period - SATISFACTORY.
2. External leakage during burn and cool-down period - SATISFACTORY.
3. Through-valve leakage during operational test - SATISFACTORY.
4. External leakage during operational test - SATISFACTORY.
5. Operability to full open position and external leakage - SATISFACTORY.

The valve was subject to a visual examination with satisfactory results and subsequently dismantled in order to verify that valves components comply with the drawing and parts list supplied by the manufacturer, while seat rings were found completely destroyed.

The manufacturers Fire Safe Test Report nº C359/09 and drawing GGC-01151 herewith attached were satisfactory checked and signed.

The above is considered in accordance with the mentioned specifications requirements, therefore the subject valve has satisfactory passed the prescribed fire test and can be also qualified as follows.

<u>DN</u>	<u>CLASS RATING</u>	<u>PN RATING</u>
80, 100, 125, 150	150#, 300#	10, 16, 25, 40



SGS Tecnos, S.A.
C/ Las Pintas nº 1, Nave B
Polígono Industrial Fontcanta
08970 Sant Joan Despí (Barcelona)
Tel.: (34) 93 477 01 71 - 93 477 01 69
Fax.: (34) 93 673 15 00

Surveyor Javier Aranda García

DOCUMENTS ATTACHED:

Sheets reviewed and stamped
Accordingly.

GGC-01151

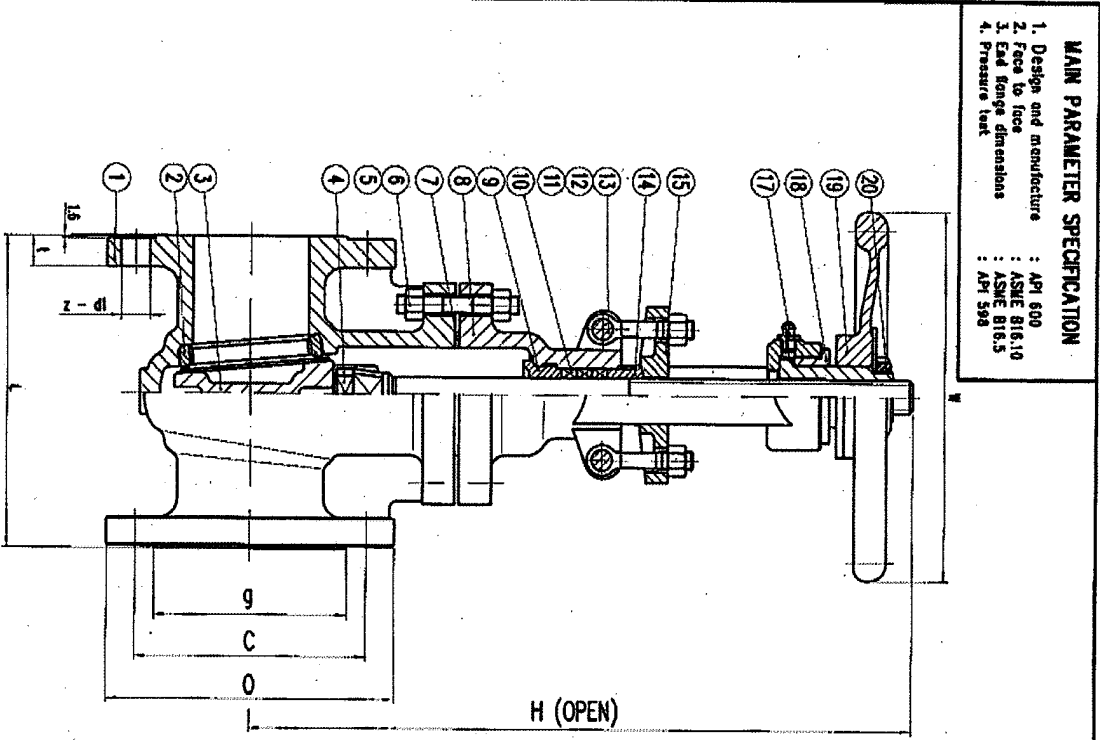

MAIN PARAMETER SPECIFICATION

1. Design and manufacture : API 600
 2. Face to face : ASME B16.10
 3. End flange dimensions : ASME B16.5
 4. Pressure test : API 598

ITEM	Identification Number	NPS		L	H	W	Ø	C	g	t	2-d1
		IN	MIL								
257	CN-ISV-0145	3"	88	263	512	230	190	152.5	127	19	4-ø19
259	CN-ISV-0147	3"	89	203	512	190	152.5	127	19	19	4-ø19
266	CN-ISV-0171	4"	100	229	595	250	229	190.5	157	24	8-ø19
256	CN-ISV-0143	8"	200	292	945	350	343	298.5	270	29	8-ø22
258	CN-ISV-0146	8"	200	292	965	350	343	298.5	270	29	8-ø22

20	H.H. LOCK NUT	CARBON ST.									
19	HANDWHEEL	CARBON ST.									
18	BEARING NUT	CARBON ST.									
17	OL. CAP	CARBON ST.									
16	STEEL NUT	A 439 Gr 102									
15	BLAND FLANGE	A 216 Gr WC9									
14	BLAND FLANGE	A 182 F6									
13	BLAND FLANGE	A 105 B7									
12	BLM	CARBON ST.									
11	BLAND NUT	A 193 ZH									
10	STEEL PACKING	DUCONITE + CL									
9	SHOCKWAVE BUSHING	A 102 F6									
8	SHOCKWAVE BUSHING	A 102 F6									
7	SHOCKWAVE BUSHING	A 102 F6									
6	ROCKET NUT	S.S. 304 + GRAPHITE									
5	ROCKET NUT	A 193 B7									
4	STEEL	A 182 F6									
3	WEDGE	A 216 Gr WC9 + ER410									
2	SEAT RING	A 105 + STL									
1	BODY	A 216 Gr WC9									

This drawing is the property of SGS. It is not to be reproduced, stored in a retrieval system, or transmitted in any form or by any means, electronic, mechanical, photocopying, recording, or by any information storage and retrieval system, without the prior written permission of SGS.

Rev.	Modifications	Date	By	Appr.
0	First Issue	30-09-08	JL.V.	
1	Change	30-09-08	J. Rubio	

Weight: **As per Eng.**

Substituted by: **As per Eng.**

Substituted by: **As per Eng.**

GENERAL ASSEMBLY DRAWING
GATE VALVE DN-3" CLASS-150

JC VALVES

T46 NF

Drawing n°: **GGC-01151**