

st STARLINE[®]
forged steel ball valves

STARLINE

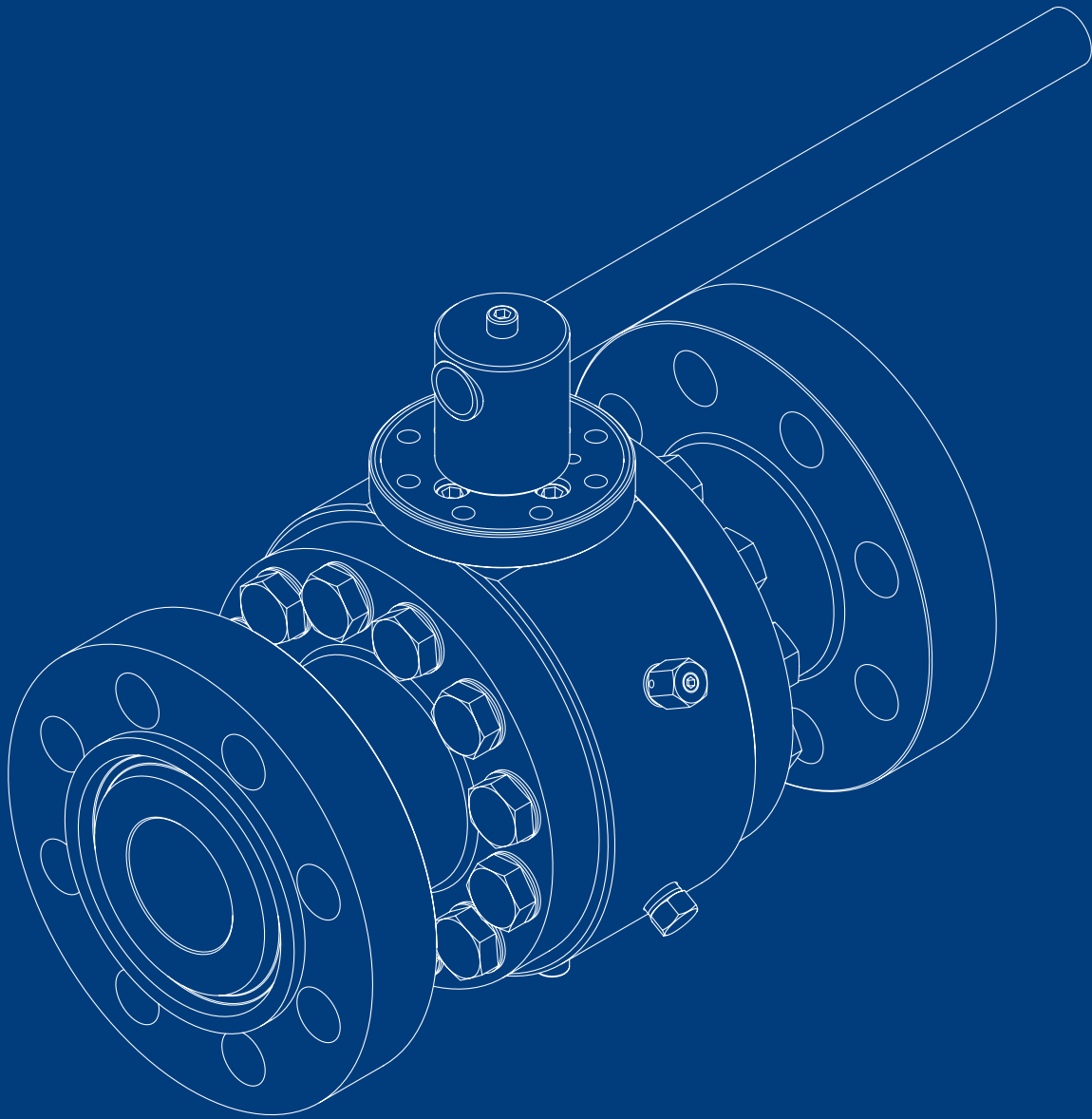

SUBSEA

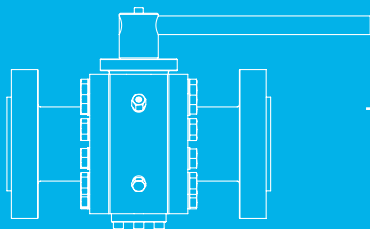

BALL VALVES

Starline manufactures a complete line of Subsea ball valves.

Our Subsea ball valves are available in an extensive range of designs, materials, sizes and pressure classes and are in full conformance with API 6DSS, NACE and ASME VIII specifications. Starline uses only high-quality forged materials inspected & tested to International Standards and utilizes advanced manufacturing technology with special emphasis on safety, quality, and long service life of our products. The forging material can ensure the best rigidity and strength.

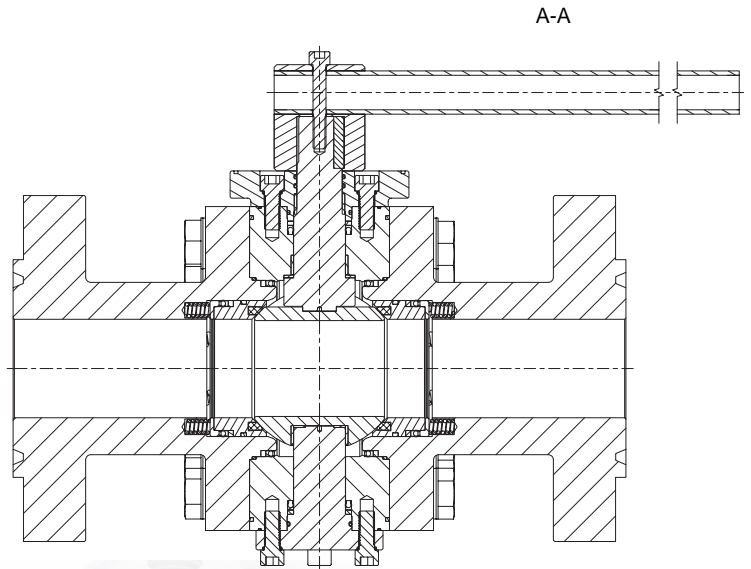

MAIN FEATURES

- Trunnion mounted ball valve concept to reduce the operating torque
- Compact two/three pieces design is available on request
- Double block and bleed version is available on request
- Anti-Blow Out stem design
- Standard seat design is single piston effect. Double piston effect sealing barrier available on request.
- Antistatic device
- Stem&body special seals to prevent the ingress of sea water into the valve body

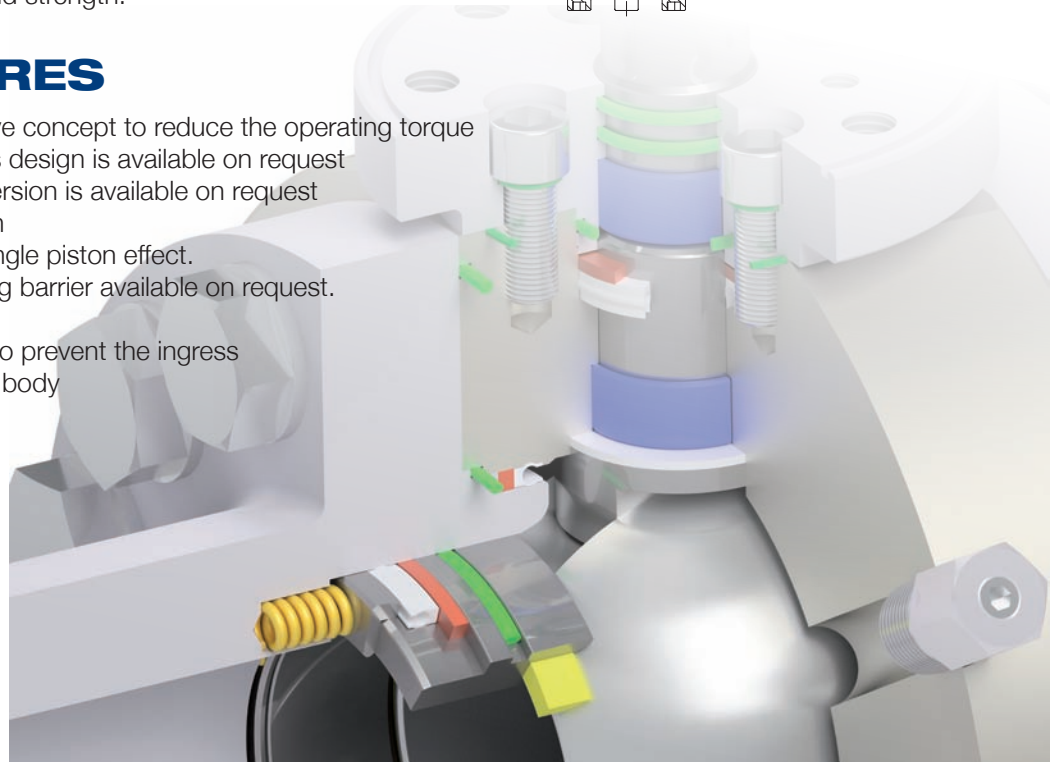

SPECIAL SEALS

FEA

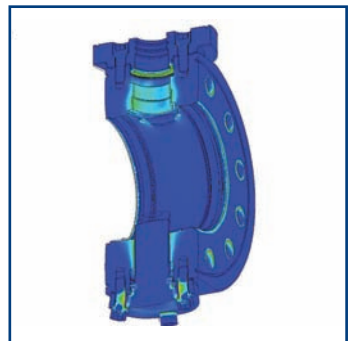
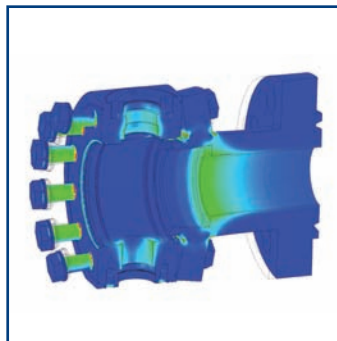
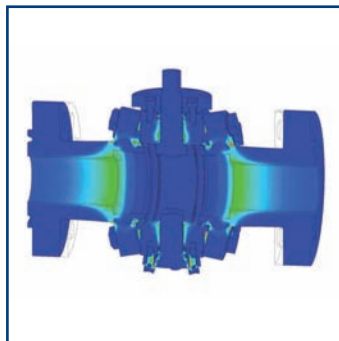

Starline uses the FEA for designing its Subsea valves. Finite Element Analysis (FEA) is a very important step of the development stage and ensures the best possible performance requirements. Valves operational problems, pressure/temperature related deformations and flow-related forces within a valve can be evaluated.

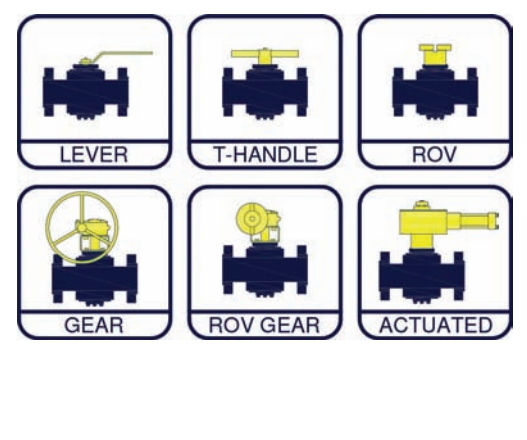
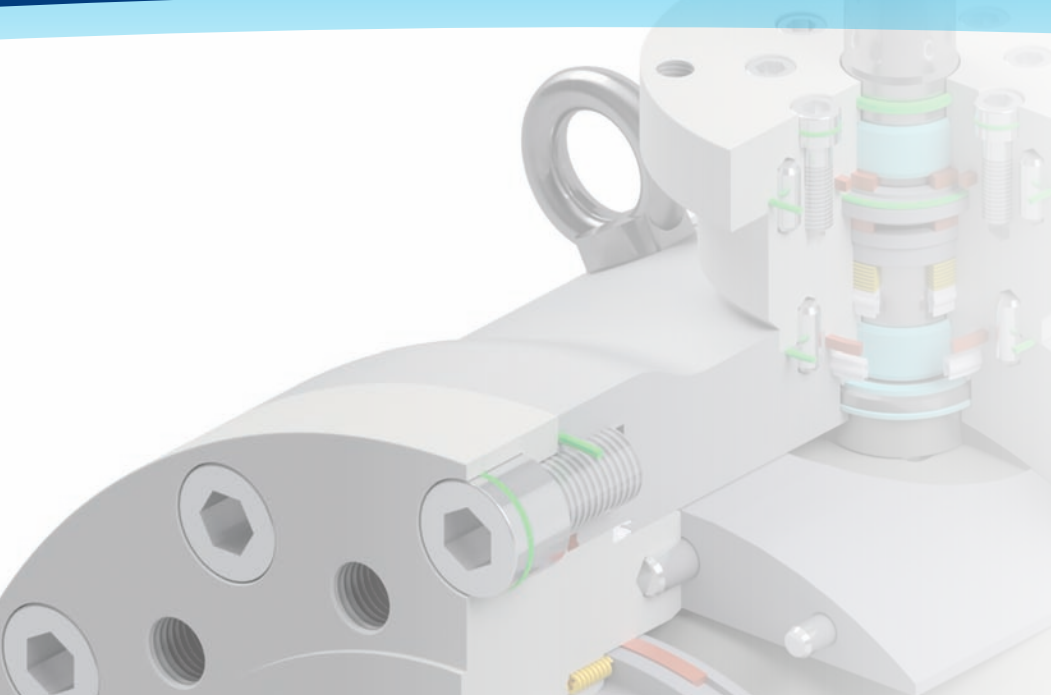

Starline performs in its facilities different non-destructive testing like ultrasonic, penetrant test, magnetic particles as defined by ASME B16.34.

Starline personnel performing NDT is trained and qualified to EN 473/ ASNT-SNT-TC-1A. According to the customer needs, Starline provide along with the subsea ball valve body:

- following usual end connection: BW, swivel flanges, integral flange (ASME or special)
- following available operator: lever/ROV - gear (manual/ROV) - Hydraulic actuator



Since its foundation on 1976 Starline has been focus only on production of Ball Valves in Forged Materials. After more than 40 Years the imprinting philosophy is still present and the base for the Company growth and success. Starting from the experience on the floating valves during the years, Starline has developed a wide and complete range of ball valves in different materials and executions introducing Trunnion Mounted design, Single and Double Block and Bleed, Metal to Metal,

Cryogenic and High temperature design. Today Starline with a production capacity of 250.000 valves/year, a complete size range and pressure ratings 1/2" to 36" – class 150- 2500lbs, API6A rate 3000-15000PSI in all the possible configurations and materials, is considered both by Customers and other Valve Manufacturers one of the Worldwide Market Leaders in Upstream Oil & Gas Applications which represent more than 70% of the final products destination.

PHILOSOPHY

Starline's philosophy is based on the achievement of the standardization of the highest quality requirements in each single product. All materials used are mandatory produced in Western Europe and all forging companies are located in Italy.

A product **FULLY MADE IN ITALY**



REFERENCES

- ADCO
- ADGAS
- ADMA-OPCO
- BP
- DSME
- ENI
- EXXON MOBIL
- GASCO
- GRT GAZ
- GAZPROM
- HYUNDAI (HHI)
- INPEX
- JGC CORPORATION
- KBR
- KNPC
- KOC
- NIOC
- NISOC
- NPCC
- PDO
- PETROBRAS
- PETROFAC
- PTSC
- PTTEP
- QATARGAS
- SAIPEM
- SAMSUNG (SHI)
- SHELL CHEVRON
- SNAMPROGETTI
- STATOIL
- TECHNIP
- TECNIMONT
- TOTAL E&P
- TOYO
- ZADCO

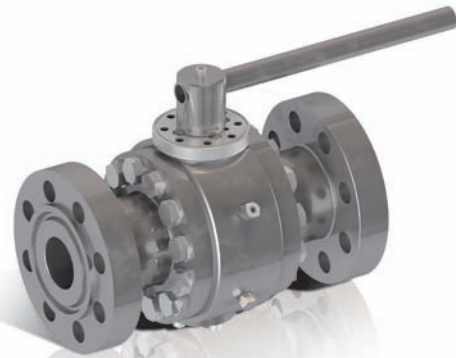

All the Starline Subsea ball valves are identified on proper name plate and on valve body as required by API 6DSS, MSS-SP 25, ASME B16.34. Nameplate indicates all information on rating, size, valve body and trim material, customer tags. Body marking includes material designations (per ASTM) and heat code.



STANDARDS AND CERTIFICATIONS

ISO 9001: 2008	API 6D
PED 2014/68/EU MOD.H CAT.3	API 6DSS
ATEX 2014/34/EU	API 6A ISO10423
SIL 3	FIRESAFE API607-API 6FA- ISO10497
CU-TR	BS 6364
ASME B16.5 – ASME B16.10	NACE MR0175 – NACE MR0103
ASME B16.25 – ASME B16.34	SHELL TAT
ASME B16.11 – ASME B1.20.1	ISO 15848
ASME VIII	



Type in 'StarlineAR'
and DOWNLOAD NOW

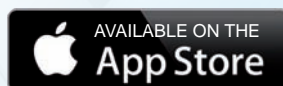



Starline S.p.A. - Società Unipersonale

Via dei Livelli di Sopra, 11 - 24060 Costa di Mezzate (BG) Italy
tel. +39 035 958041 / +39 035 958102 - fax +39 035 958413
www.starline.it - starline@starline.it

STARLINE BALL VALVES Ltd.

Unit 6, Interlink Way South
Bardon Hill, Coalville, Leicestershire, LE67 1PH
UK
Phone.: +44 (0) 1530 815818
Fax.: +44 (0) 1530 815819
starline@acvalvealliance.com
www.acvalvealliance.com

STARLINE FRANCE S.a.r.l.

7, Parc d'Activités de la Verdière
13880 Velaux
FRANCE
Phone : +33 (0) 442878400
Fax : +33 (0) 442878404
infos@star-line.fr
www.star-line.fr

STARLINE VALVES OY

Koivuhaantie, 2-4 C
01510 Vantaa
FINLAND
Phone: +358 (0) 98787711
Fax : +358 (0) 98787221
starline@starline.fi
www.starline.fi