

USER INSTRUCTIONS

**Sambo™ Declutch Gear
Series**

**Installation
Operation
Maintenance**



Global Supply Line is proud to be an Australian distributor, agent and stockist for Sambo gearboxes. Full stock list at our website: www.globalsupplyline.com.au
You can contact us here: sales@globalsupplyline.com.au

Sambo21.com

Contents

1	Introduction	3
	Purpose	3
	User Safety	3
	Trial-run	
	Operation	
	Maintenance	
	IP GRADE & Environment Conditions	
2	Inspection, Installation and Mounting Procedures	5
	Initial Inspection and Storage Instructions	6
	Inspection and Recording	6
	Storage Procedure	6
	General Mounting Instructions	7
	Assembly Positions	8
	Setting Position Limit Stops	9
	Operating	11
3	Lubrication	13
4	Declutch gearbox Model & Spec	14

1

Introduction

Purpose

The installation and maintenance manual (IOM) explains how to install and maintain the Sambo Declutch gear operator. Information on installation, disassembly, reassembly, lubrication and spare parts is provided.

User Safety

Safety notices in this manual detail precautions the user must take to reduce the risk of personal injury and damage to the equipment. The user must read and be familiar with these instructions before attempting installation, operation or maintenance. Failure to observe these precautions could result in serious bodily injury, damage to the equipment, voiding of the warranty, or operational difficulty.

Safety notice is presented in this manual in three forms:

- C **WARNING:** Refers to personal safety. Alerts the user to potential danger. Failure to follow warning notices could result in personal injury or death.

- a **CAUTION:** Directs the user's attention to general precautions that, if not followed, could result in personal injury and/or equipment damage.

NOTE: Highlights information critical to the user's understanding of the operator's installation and operation. Trial-run Check with your process or safety engineer for all measures that must be taken to protect against product discrepancies before trial-run.

SAMBO Industrial co., Ltd. is not liable for such damages to gearbox, valve, and pneumatic caused by inaccurate settings by the user.

Operation

For smooth operation, the user must follow below instructions.

- Always check for any possible danger before operating.
- To avoid possible injury to personnel or damage to products, safety terms must be strictly adhered to.
- In case of discrepancies, please contact SAMBO Industrial co., Ltd.
- All recognized regulations for safety and obligatory accident prevention directives valid in the country of use must be followed.

Maintenance

Product users and maintenance personnel should always follow this instruction for optimal operation.

Declutch gear should not be modified or replaced without first contacting the manufacturer. The following instructions are designed to assist in maintenance and optimal operation.

- Check for bolt tightening on Valve and pneumatic mounting bolts.
- Check for bolt tightening on gearbox mounting bolts.
- Check for grease leakage.
- Perform trial-run on every 3 months and perform operation test on every 6 months.

IP GRADE

IP67 waterproof and dustproof standard.

IP68 option is available.

(IP68 rating for inside gearbox only)

Additional parts are required for IP68 ratings on SHAFT and COUPLING.

Wide temperature range from 100 ~ -20 with corresponding high and low temperature grease. Not suitable for extreme conditions. Please inquire for extreme environment conditions.

2

Inspection, Installation and Mounting Procedures

Figure 2.1 – Typical Delutch Gear Exploded View

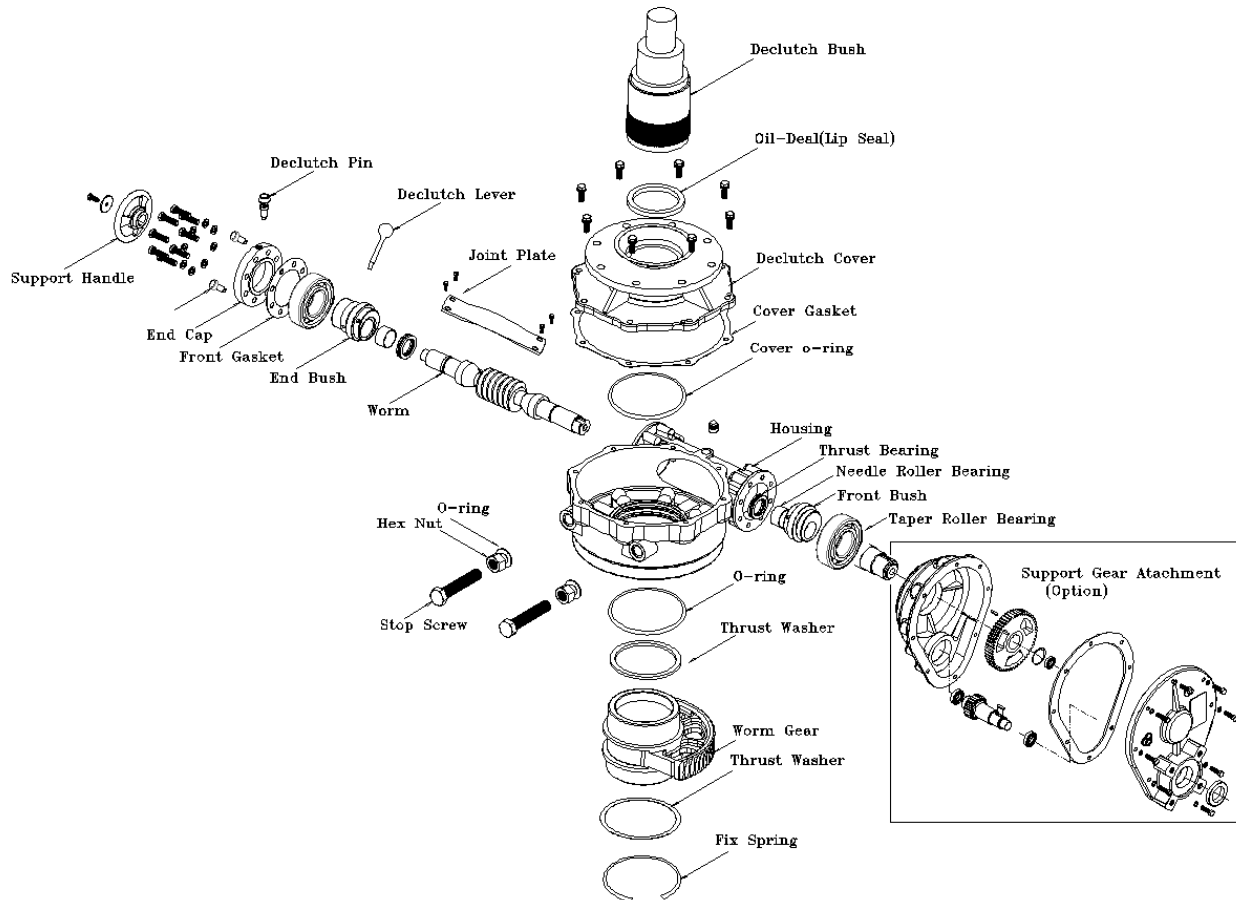

- c **WARNING:** Do not manually operate the Declutch worm operator with devices other than the installed handwheel or wrench nut. Using additive force devices (cheater bars, wheel wrenches, pipe wrenches, or other devices of this nature) on the operator handwheel, wrench or wrench nut may cause serious personal injury and/or damage to the operator or valve.

Initial Inspection and Storage Instructions

- C **WARNING:** Read this installation and maintenance manual carefully and completely before attempting to store the operator. If an electric actuator is attached to the WG manual operator, be aware of the electrical hazards. Consult the electric actuator installation and maintenance manual for guidance.

Inspection and Recording

Upon receipt of the operator, inspect the condition of the equipment, and record nameplate information.

1. Carefully remove operator from shipping carton or skid. Thoroughly examine the equipment for any physical damage that may have occurred during shipment. If damaged, immediately report the damage to the transport company.
2. A nameplate is attached to each operator with the following information:
 - Operator size
 - Assembly position
 - Order number
 - Serial number
 - Customer tagging

Record this information for future reference, e.g., ordering parts, or obtaining further information.

Storage Procedure

NOTE: The following is the recommended storage procedure to retain maximum product integrity during storage. Failure to comply with recommended procedure will void the warranty.

Storage (less than one year)

Store operators on wooden skids to protect the machined mounting flange. Place the wooden skids containing the operators in a clean, dry, protected warehouse. If the operators must be stored outside, they must be covered in polyethylene protection with silica gel crystals to absorb moisture. If an pneumatic actuator is attached to the WG, refer to the storage procedures in its respective manual for appropriate storage procedures. Rotate input shafts every three months to mix the lubricant.

General Mounting Instructions

SBWG-DC,DCM is 1/4 turn gearbox especially designed to operate with pneumatic actuator. This device allows manual operation during installing, breakdown, and breakage if when air resource is not loaded.

Pneumatic actuator installed gearbox is available.

Mounting to the Valve

1. Declutch gearbox is manufactured CLOSE position. (Standard)
Note: Please inquire if manufactured OPEN position.
2. Declutch gearbox is assembled with Stem bush installed. (Hand wheel not installed)
3. Please check gearbox and valve flange bolt hole before installation.
The stem bush hole should be concentric with the valve shaft.

Note: If stem bush bore key position is not correct, please follow below order.

1. Remove fix spring(2).
2. Remove stem bush(2).
3. Adjust bush bore key position to concentric with the valve shaft.

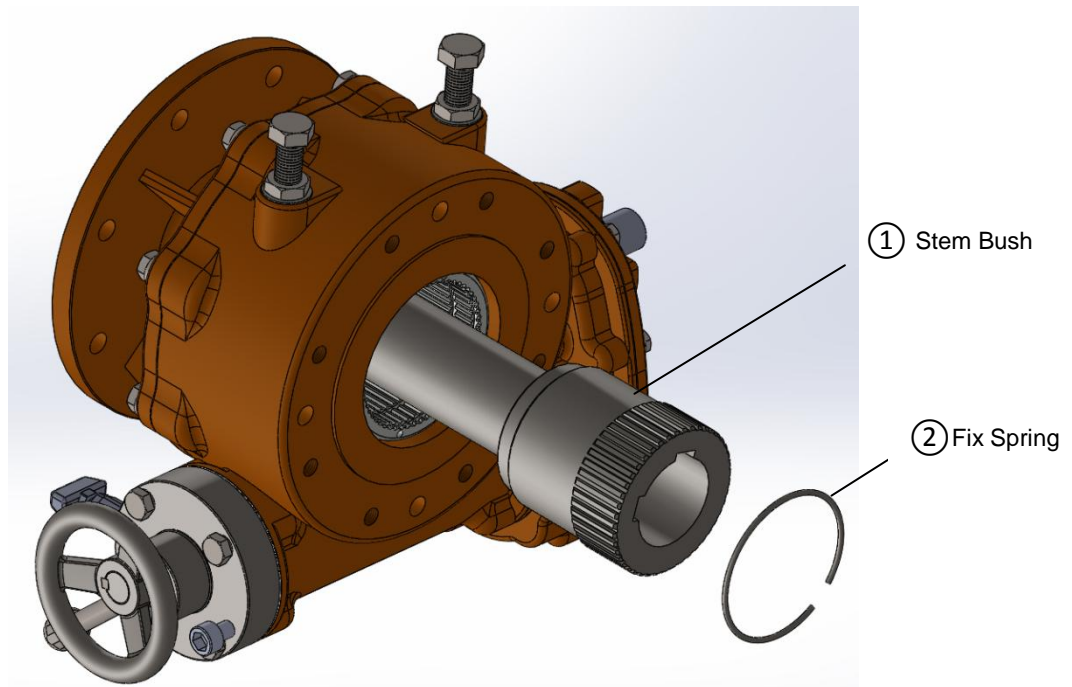

4. Valve should be at CLOSE position, if not, please set valve to CLOSE position.
5. Please turn input shaft Clockwise for FULL CLOSE position.
Note: The device has 4 different assembly position, please refer figure-2.
6. In order to mount the device with studbolts, the user must install studbolts to the device before mounting.-
7. Sealant between the valve and the gearbox is recommended.
8. The device should be correctly installed with bolts.
Note: For bolt torque tightness data please refer table-1.

Sambo DECLUTCH Series Worm Gear Operator

figure 2 Assembly Position

position A: STAND ASSEMBLY POSITION

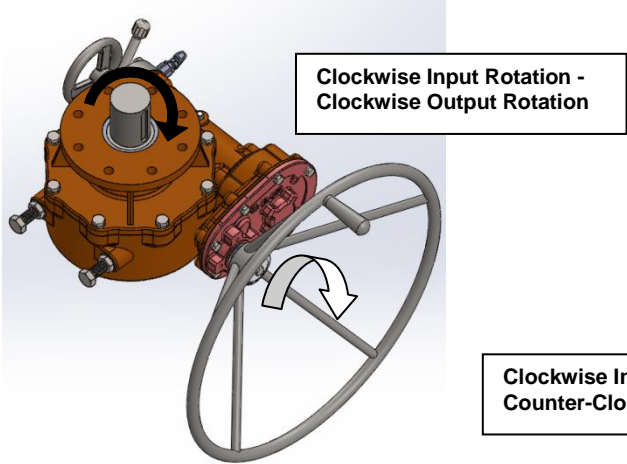

position B: Optional Assembly Position

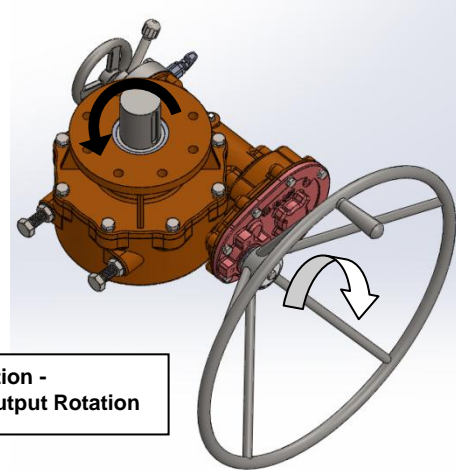

position C: Optional Assembly Position

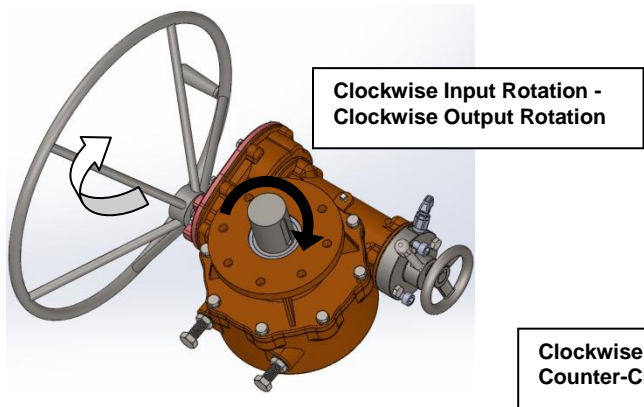

position D: Optional Assembly Position

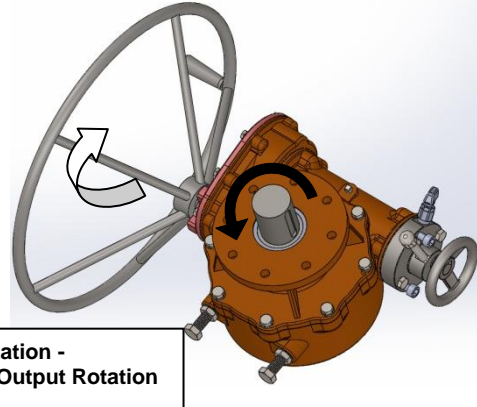

Table 1 For tightening, refer to standard VDI 2230

SCREW SIZE	TYPE	TORQUE TIGHTNESS (10.9 GRADE) N.m	TYPE	TORQUE TIGHTNESS (10.9 GRADE) N.m
M4	SOCKET HEAD	4 ~ 6	HEXAGON HEAD	
M5		7 ~ 12		
M6		13 ~ 21		8 ~ 12
M8		32 ~ 50		19 ~ 30
M10		63 ~ 87		38 ~ 60
M12		108 ~ 149		66 ~ 104
M16		264 ~ 370		164 ~ 264
M20		517 ~ 725		320 ~ 516
M24		890 ~ 1246		550 ~ 887
M30		1775 ~ 2498		1104 ~ 1793
M36	3082 ~ 4349	1923 ~ 3140		

Setting Position Limit Stops

Refer to Figure 3

1. Mount declutch onto the Valve.
2. Disconnect air pressure and electrical power from actuator if necessary.
3. Set declutch to MANUAL mode. (REMOTE is factory standard)
 - 1) Pull out the declutch pin out of locking position.
 - 2) Rotate the engage-disengage lever 90 degrees to MANUAL mode.
 - 3) Drop declutch pin into the indexed position.
4. Set the device to FULL CLOSE position by tightening the hand wheel further clockwise.
If FULL CLOSE position is not reached, unscrew and reset the stop bolts then try set the device to FULL CLOSE position.
(Unscrew the nuts along with the stop bolts. Be careful for not to damage Oil-seal)
5. Tighten the stop bolts until complete stop.

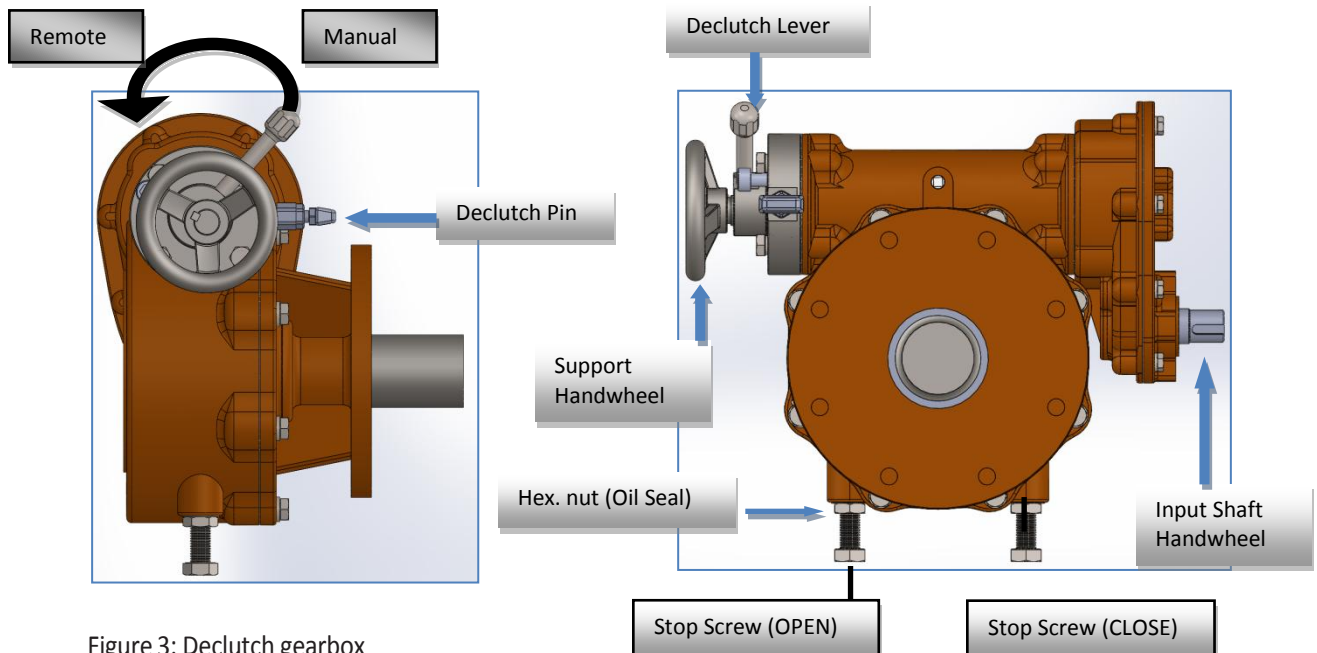

Figure 3: Declutch gearbox

6. Set the device to FULL OPEN position by turning the hand wheel counter-clockwise.
7. If FULL OPEN position is not reached, unscrew the stop bolts then try set the device to FULL OPEN position.
(Unscrew the nuts along with the stop bolts. Be careful for not to damage Oil-seal)
Tighten the stop bolts until complete stop.

Sambo DECLUTCH Series Worm Gear Operator

8. Set declutch to REMOTE mode.
 - 1) Pull out the declutch pin out of locking position.
 - 2) Rotate the engage-disengage lever 90 degrees to REMOTE mode.
 - 3) Drop declutch pin into the indexed position.
9. The declutch actuator is ready for both manual and automatic operation. (Gear is disengaged)
10. Pre-Installation.
 - 1) Adjust stop bolts for your factory standard.
 - 2) Adjust the worm gear shaft hole to be concentric with the valve shaft at CLOSE position.

Note: The stop bolts are adjustable to +/- 5° of total travel to allow for proper positioning of the worm gear quadrant.

Operating

Always check declutch gearbox mode(REMOTE or MANUAL) before operating the device.

In MANUAL mode, serious damage may occur when operating the device with the pneumatic actuator.

Refer to Figure 4

1. The declutch gearbox assembled with 2 hand wheel. The hand wheel must operate with input shaft.
(Support hand wheel is used in case for improper gear engagement.)
2. Please set the device in MANUAL mode before operating manually.
 - 1) Pull out the declutch pin out of locking position.
 - 2) Rotate the engage-disengage lever 90 degrees to MANUAL mode.
 - 3) Drop declutch pin into the indexed position.
3. Turning the hand wheel clockwise will advance the valve position to CLOSE position.

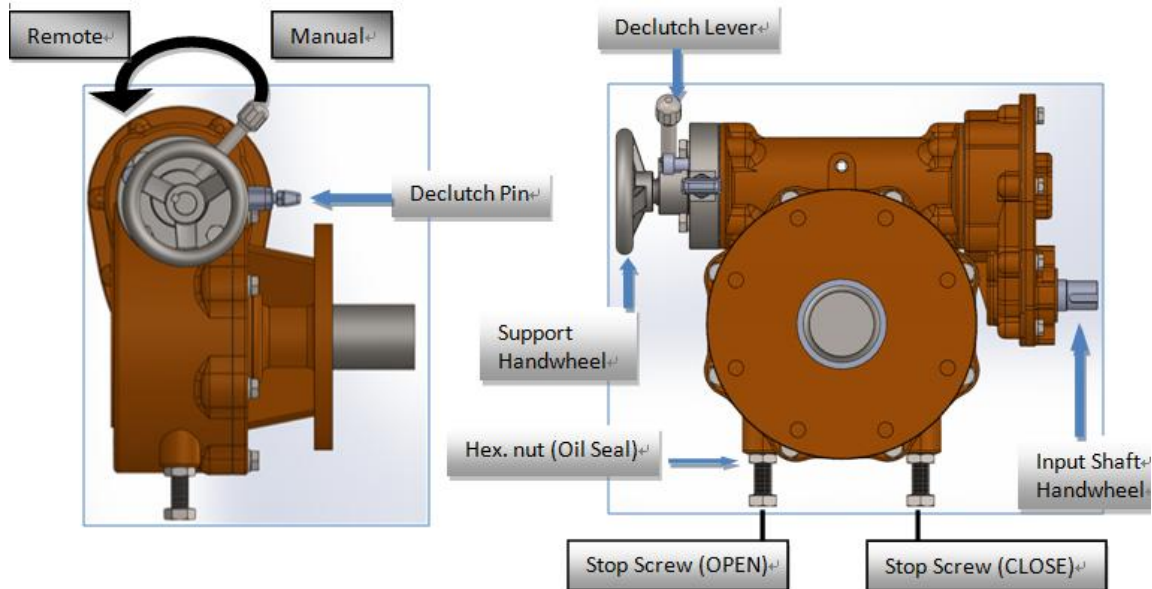

Figure 4: Declutch gearbox

Sambo DECLUTCH Series Worm Gear Operator

4. To find out the number of hand wheel turns in order for full CLOSE and OPEN, please refer to the ratio written on the nameplate.

5. Please contact the manufacturer if desired valve position is not possible.
Please send the device's specifications (nameplate) and photos to sambo@sambo21.com

6. Please follow below steps to restore automatic operation.
 - 1)
Pull out the declutch pin out of locking position.

 - 2)
Rotate the engage-disengage lever 90 degrees.
(Please turn the support hand wheel 2~3 times when the engage-disengage lever doesn't operate properly.)

 - 3)
Drop declutch pin into the indexed position.

3

Lubrication

Sambo Declutch gear are shipped with the following lubricants:

Table 3.1 – Lubricants

Product	Lubricant	Soap Base	Temperature Range
BFdcm through 08 Dcm	Zenith EPSB 2	Calcium	-20°C to 100°C (-4°F to 248°F)

NOTE: The lubricant should be checked every 18 months for manual operators.

- a **CAUTION:** Do not add a different lubricant to a Sambo operator unless it is of the same soap base as the existing lubricant, or you have received the approval of the lubricant manufacturer.

Quantity

Sambo operators are built to operate on the partial immersion principle. The primary concern regarding the amount of lubricant is whether the “worm” is totally immersed in grease. This can be verified by the use of one or more of the “fill” and “drain” plugs provided on the operator housing in most sizes.

Quality

When removing a “fill” or “drain” plug to inspect the lubricant level, remove a small amount and ensure that it is clean and free of any contaminant, including water. Should dirt, water or other foreign matter be found, the operators should be flushed with a commercial degreaser/cleaner which is non-corrosive and does not affect seal materials such as Buna-N or Viton. Repack operator with fresh lubricant.

Consistency

The main gear box lubricant should be slightly fluid, approximating a standard NLGI-2 grade consistency or less.

Alternate lubricants may be used in place of the standard lubricants supplied by Sambo, provided they are of a formulation similar to those listed above for the respective product.

4

Declutch gearbox Model & Spec

Gearbox Selection Chart

Declutch Gearbox Model	Ratio (-2SD Changeable)			Mounting Flange (ISO 5210/1)		MAXIMUM STEM (mm)	Output Torque (N.m)	Mechanical Advantage (+-10%)		
	S/D	-1S	-2SD	STANDARD	OPTION			S/D	-1S	-2SD
SBWG-BF DCM series	29			F07	-	ø20	320	10.3		
SBWG-0 DCM series	34			F10	F07	ø28	680	11.8		
SBWG-00 DCM series	38	67	266	F12	F10	ø36	980	11.8	20.6	35.9
SBWG-01 DCM series	43	75	301	F14	F10,F12	ø46	1600	12.7	22.1	38.5
SBWG-02 DCM series	46	107	429	F16	F12,F14	ø60	2500	14.2	31.3	69
SBWG-03 DCM series	50	117	467	(F20)	F14,F16	ø75	3800	15.7	34.6	76.4
SBWG-35 DCM series	52	118	471	(F20)	F14,F16	ø80	5600	16.6	36.6	80.8
SBWG-04 DCM series	56	149	958	F25	F16	ø95	9600	17.4	45.5	118.9
SBWG-05 DCM series	60	160	1026	F30	F25	ø115	14400	18.7	48.8	127.4
SBWG-55 DCM series	62	165	1061	F30	F25	ø125	21150	19.7	51.5	134.5
SBWG-06 DCM series	64	232	2088	F35	F25,F30	ø140	29250	19.3	67.1	233.5
SBWG-07 DCM series	68	247	2223	F40	F30,F35	ø180	45000	21	73.2	254.6
SBWG-75 DCM series	65	290	4645	F48	F35,F40	ø210	73350	20.4	88.8	386.1
SBWG-08 DCM series	65	290	4645	F48	F40	ø250	108900	21.5	93.7	407.6



KWAEBUP-DONG, SASANG-GU, BUSAN, KOREA

Tel. 82-51-316-2882

DECLUTCH GEARBOX OPERATION

***Caution:** Worm shaft and gear can be broken if lever is at position of "Manual" when operated by motor.

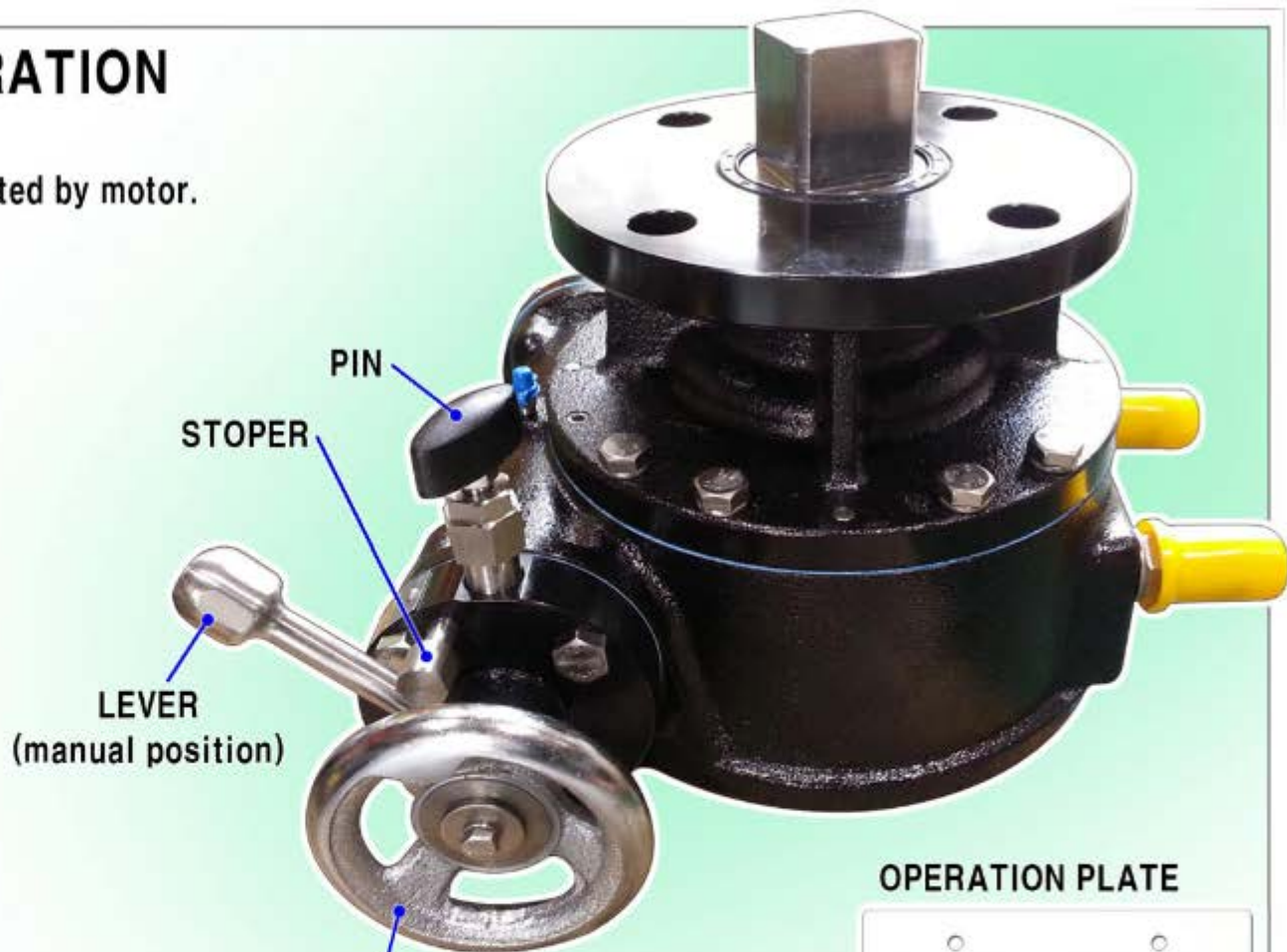
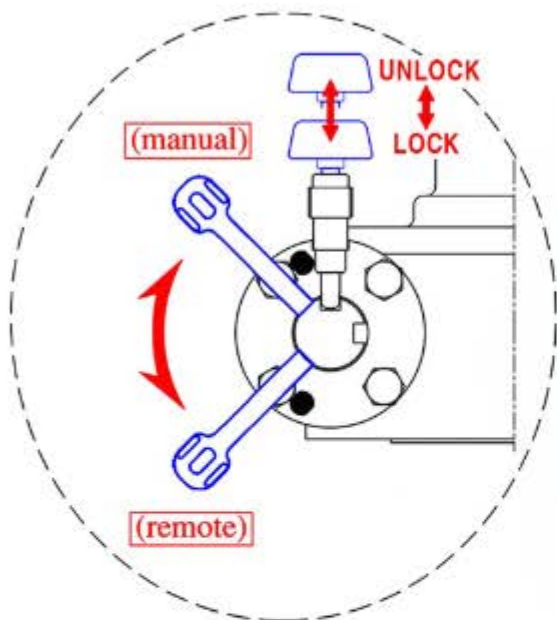

When you operate gearbox by motor, lever shall be down to "remote" position and be up to "manual" position when manually operated. You can move the lever after making lever loosen by pulling up pin.

SUPPORT HANDLE

Making position of "Remote" : Pull up the pin, then move down the lever.
 Making position of "Manual" : Pull up the pin and turn support handle at the middle of operation to align gear lever with putting up the lever.
 (DCM-1S & -2SD TYPE)

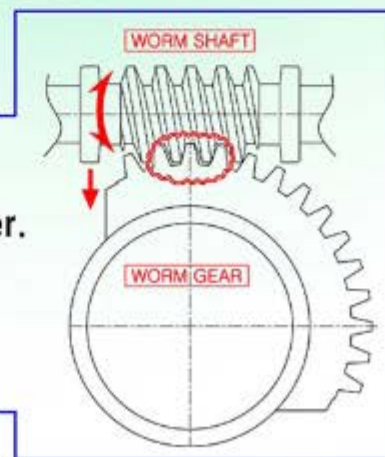

OPERATION PLATE

MANUAL OVERRIDE OPERATION

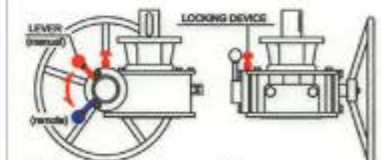

1. Pull locking device up side.
2. Then move the lever to "manual" position.
3. After fix to "manual" position, operate handle.
4. When convert to "remote" check position of manual and remote.

<CAUTION>

- Operate before check the position of manual and remote.
- When convert to "manual" position, control the position of worm shaft accord with worm gear.

SAMBO IND. CO., LTD
 WWW.SAMBO21.COM



SAMBO
 GEAR ACTUATORS

Declutchable Gearbox General Information

Torque Sizing Guidelines

- Size gear operators at 5%-10% below rated Max Output Torque
- Use highest expected valve torque value
- For spring return applications, add actuator spring torque plus valve torque (gear operator must overcome valve torque plus spring force).

Valve/Actuator/Gear Operator Engagement

Valve, actuator and segment gear are always permanently engaged when assembled. The clutch DOES NOT disconnect the actuator from the valve.

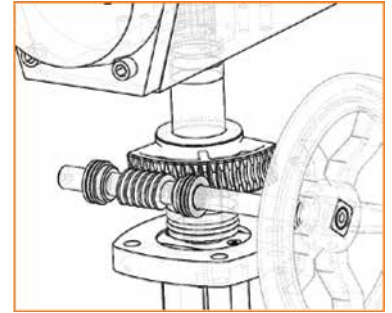

Figure 1

Clutch Lever Mechanism

Clutch Lever engages or disengages the worm gear with the segment gear, so that the segment gear spins freely. The gear operator travel stops limit the travel of the segment gear, thereby limiting rotation of the whole actuator/valve assembly.

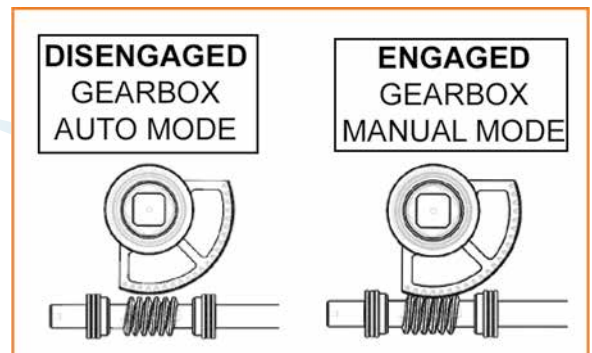

Figure 2

Integrated Block & Bleed Air Tubing Option*

This option is only available on selected models. Optional block & bleed valve system ensures actuator air is exhausted. The air bypass system is a recommended option to avoid gearbox damage due to operator error. It is not recommended for spring return actuators, only for double acting actuators. If using a separate block & bleed device, please follow manufacturer's instructions.

Air tubing from integrated block & bleed valve to actuator air ports should be as shown in Figure 3. If not using, leave ports unplugged or install dust screens/filters. Integral design shown. As an option, a separate limit switch box c/w SPDT switches can be fitted depending on model.

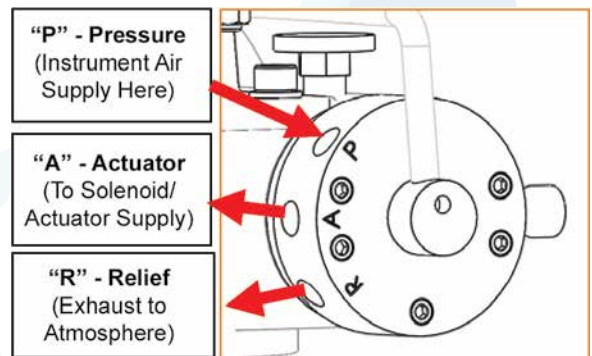

Figure 3

Note: Filter/regulator is recommended to ensure clean, dry air is supplied to block & bleed valve and actuator.

Other Options to Avoid Gearbox Damage

Declutchable gearboxes are sized based on the torque of the valve in addition to the torque of the spring (in the case of spring return actuators). However, if the operator does not release the air supply from the actuator, an engaged declutchable gearbox cannot also fight against the air supply of the actuator. This will result in damage to the gearbox. Many clients specify a manual trip system on the solenoid valve or a 3-way valve vent valve system in order to allow the operator to ensure the actuator cylinder is not under pressure prior to engaging the declutchable gearbox.



Caution

Never operate the actuator with the gearbox engaged or the gearbox will be damaged. Gearbox is designed to turn the valve & actuator, it is not designed to be turned by the actuator.

DECLUTCH

RETAINER

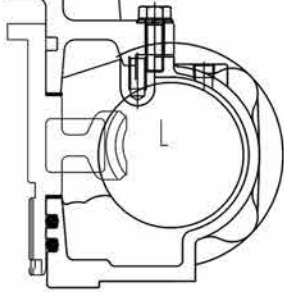
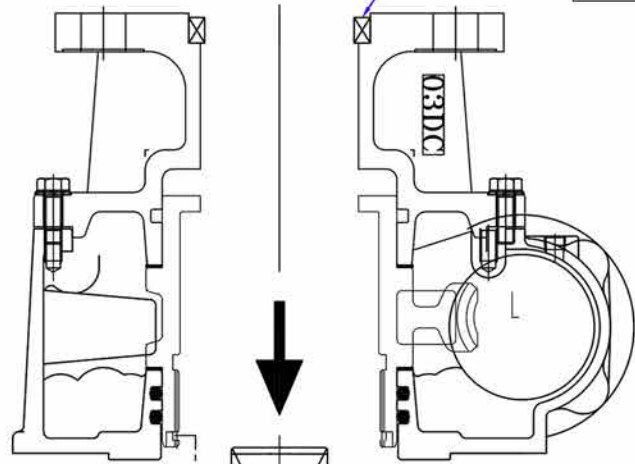

STEM BUSH



STEM BUSH

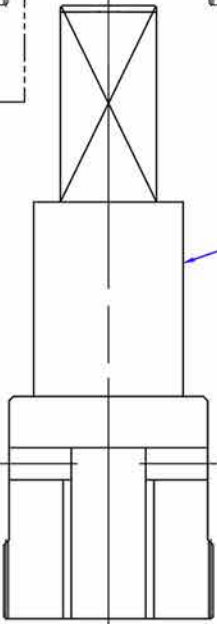

FIX SPRING

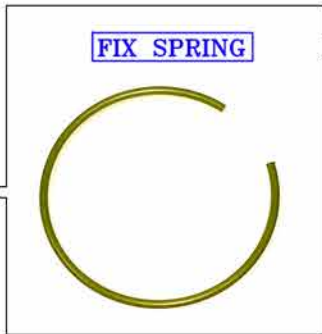

FIX SPRING



HOW TO REMOVE STEM BUSH SAMBO DECLUTCHABLE GEARBOX

