

Original instructions

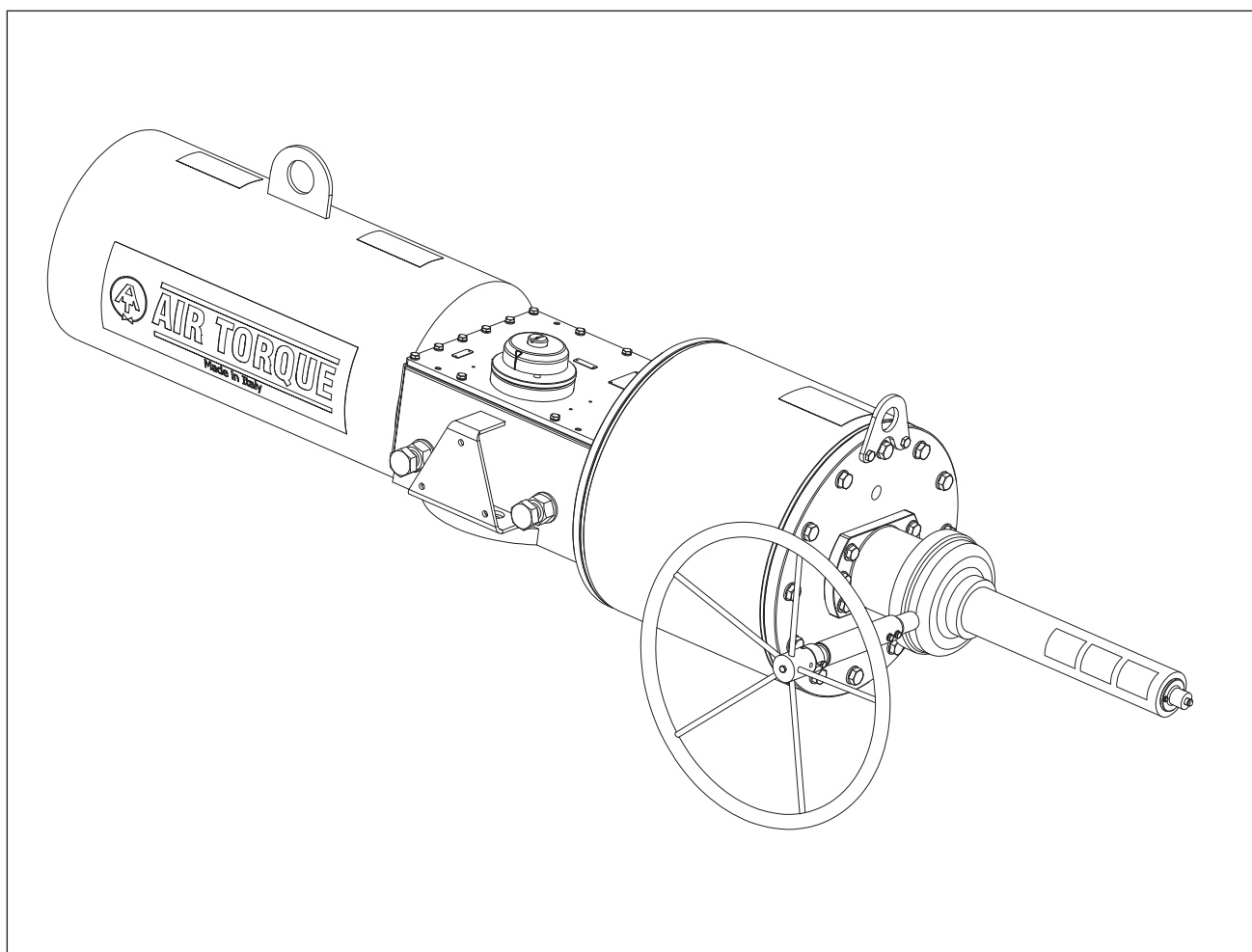

BEVEL GEAR

Manual override for AT-HD series actuators

Note on these mounting and operating instructions

These mounting and operating instructions assist you in mounting and operating the device safely. The instructions are binding for handling AIR TORQUE devices. The images shown in these instructions are for illustration purposes only. The actual product may vary.

- For the safe and proper use of these instructions, read them carefully and keep them for later reference.
- If you have any questions about these instructions, contact AIR TORQUE's After-sales Service Department (aftersales@airtorque.it).



The mounting and operating instructions for the devices are included in the scope of delivery. The latest documentation is available on our website at www.airtorque.it

Definition of signal words

⚠ DANGER

Hazardous situations which, if not avoided, will result in death or serious injury

⚠ WARNING

Hazardous situations which, if not avoided, could result in death or serious injury

ⓘ NOTICE

Property damage message or malfunction

i Note

Additional information

💡 Tip

Recommended action

1	Safety instructions and measures	1-1
1.1	Notes on possible severe personal injury	1-2
1.2	Notes on possible personal injury	1-2
1.3	Notes on possible property damage	1-2
1.4	Warnings on the device	1-3
2	Markings on the device	2-1
2.1	Nameplate	2-1
2.2	Handwheel rotation indication marking.....	2-1
3	Design and principle of operation	3-1
3.1	Direction of action and fail position	3-1
3.2	Versions	3-1
3.3	Technical data	3-1
4	Shipment and on-site transport	4-1
4.1	Accepting the delivered goods	4-1
4.2	Removing the packaging from the actuator with bevel gear	4-1
4.3	Transporting and lifting the actuator with bevel gear	4-1
4.3.1	Transporting the actuator with bevel gear	4-1
4.3.2	Lifting the actuator with bevel gear	4-1
4.4	Storing the actuator with bevel gear	4-2
5	Mounting and assembly	5-1
5.1	Preparation for installation	5-1
5.2	Control and signal devices assembly	5-1
5.3	Mounting the actuator with bevel gear over the valve	5-1
6	Start-up	6-1
7	Operation	7-1
7.1	Bevel gear neutral position	7-1
7.2	Actuator operated with supply pressure	7-2
7.2	Manual operation with bevel gear	7-2
8	Malfunctions	8-1
8.1	Troubleshooting	8-1
8.2	Emergency action	8-1
9	Service	9-1
9.1	Preparation for servicing	9-1
9.2	Disassembly	9-1
9.3	Service operations	9-2
9.4	Reassembly	9-2
10	Decommissioning	10-1
11	Removal	11-1
12	Repairs	12-1
13	Disposal	13-1
14	Certificates	14-1
15	Annex	15-1
15.1	Tools	15-1
15.2	Tightening torques and sequences	15-1
15.3	Lubricants	15-2
15.4	Threadlocker	15-2

1 Safety instructions and measures

Intended use

The AIR TORQUE bevel gear is a manual override for AT-HD Series actuators intended to manually move the actuator and the valve upon air supply/electrical failure.

The actuator with bevel gear is designed to operate under exactly defined conditions (e.g. temperature, travel). Therefore, operators must ensure that the actuator with bevel gear is only used in operating conditions that meet the specifications used for sizing the bevel gear and the actuator at the ordering stage. In case operators intend to use the bevel gear and the actuator in other applications or conditions than specified, contact AIR TORQUE.

AIR TORQUE does not assume any liability for damage resulting from the failure to use the device for its intended purpose or for damage caused by external forces or any other external factors.

➔ Refer to the technical data and nameplate for limits and fields of application as well as possible uses.

Reasonably foreseeable misuse

The actuator with bevel gear is not suitable for the following applications:

- Use outside the limits defined during sizing and by the technical data.
- Use outside the limits defined by the accessories connected to the actuator.

Furthermore, the following activities do not comply with the intended use:

- Use of non-original spare parts
- Performing service and repair work not described in these instructions

Qualifications of operating personnel

The actuator with bevel gear must be mounted, started up, serviced and repaired by fully trained and qualified personnel only; the accepted industry codes and practices are to be observed. According to these mounting and operating instructions, trained personnel refers to individuals who are able to judge the work they are assigned to and recognize possible hazards due to their specialized training, their knowledge and experience as well as their knowledge of the applicable standards.

Personal protective equipment

We recommend wearing the following personal protective equipment when handling the AIR TORQUE bevel gear and actuators:

- Protective gloves and safety footwear when mounting or removing the actuator
 - Eye protection and hearing protection while the actuator is operating.
- ➔ Check with the plant operator for details on further protective equipment.

Revisions and other modifications

Revisions, conversions or other modifications of the product are not authorized by AIR TORQUE. They are performed at the user's own risk and may lead to safety hazards, for example. Furthermore, the product may no longer meet the requirements for its intended use.

Safety devices

The AIR TORQUE bevel gears can be locked in the resting position with a padlock while the actuator is pressurised to avoid any accidental adjustment of the actuator travel. The padlock is available on request.

Warning against residual hazards

To avoid personal injury or property damage, plant operators and operating personnel must prevent hazards that could be caused in the actuator with bevel gear by the signal pressure, stored spring energy or moving parts by taking appropriate precautions. They must observe all hazard statements, warning and caution notes in these mounting and operating instructions.

Responsibilities of the operator

The operator is responsible for proper operation and compliance with the safety regulations. Operators are obliged to provide these mounting and operating instructions as well as the referenced documents to the operating personnel and to instruct them in proper operation.

Furthermore, the operator must ensure that operating personnel or third persons are not exposed to any danger.

These instructions should not supersede or replace any customer's plant safety or work procedures. If a conflict arises between these instructions and the customer's procedures, the differences should be resolved in writing between an authorized customer's representative and an authorized AIR TORQUE representative.

Responsibilities of operating personnel

Operating personnel must read and understand these mounting and operating instructions as well as the referenced documents and observe the specified hazard statements, warnings and caution notes. Furthermore, the operating personnel must be familiar with the applicable health, safety and accident prevention regulations and comply with them.

Referenced standards and regulations

- AIR TORQUE actuators with bevel gear are designed, produced and classified according to the European Atex directive 2014/34/EU. Before using the actuators with bevel gear in potentially explosive atmosphere areas, verify the actuator and the bevel gear compliance with the required ATEX classification.
- ➔ Refer to the nameplate and the ATEX safety instructions.
- AT-HD Series actuators with bevel gear are SIL certificated.
- ➔ Refer to the SIL Certificate available from AIR TORQUE for the AT-HD Series actuators with bevel gear SIL capability.

Safety instructions and measures

- Referring to Machine Directive 2006/42/EC, actuators with bevel gear are classified as “partly machinery” (see Declaration of incorporation).
Therefore, the actuator and the bevel gear cannot be put into service until the machinery and/or the final system, where the actuator with bevel is incorporated, will be declared in compliance with the requirements of the Directive.
- The AIR TORQUE pneumatic actuators with bevel gear are designed according to the criteria of Article 1, paragraph 2. j) ii) of the Pressure equipment directive (PED) 2014/68/EU. Therefore, according to the directive 2014/68/EU they are not to be considered pressure equipments.
- Refer to the EU Declaration of Conformity available from AIR TORQUE.
- The AIR TORQUE actuators with bevel gear are in compliance with the TR CU 10/2011 and TR CU 12/2011.

Referenced documentation

The further documents apply in addition to these mounting and operating instructions:

- EB AT-HD mounting and operating instructions for the AIR TORQUE AT-HD actuators.
- Mounting and operating instructions for the valve, available from the valve manufacturer,
- Mounting and operating instructions for control and signal devices (positioner, solenoid valve, etc.) available from devices manufacturer,
- ATEX safety manual,
- SIL safety manual for use in safety-instrumented systems.

1.1 Notes on possible severe personal injury

⚠ DANGER

The bevel gear poses no hazard with possible severe personal injury.

- Observe hazard statements in the associated actuator documentation.

1.2 Notes on possible personal injury

⚠ WARNING

Risk of lifting equipment tipping over and risk of damage to lifting accessories due to exceeding the rated lifting capacity.

- Use only approved lifting equipment and accessories whose maximum lifting capacity is higher than the actuator weight (including the packaging, if applicable).

Crush hazard arising from moving parts.

The actuator with bevel gear and the valve assembly contain moving parts, which can injure hands or fingers.

- Do not touch or insert hands or finger into moving parts.
- Before starting any work on the bevel gear disconnect all pneumatic/hydraulic/electrical supplies and discharge the pressure from the actuator.

Risk of personal injury through incorrect operation, use or installation as a result of information on the actuator being illegible.

Over time, markings, labels and nameplates on the actuator and the bevel gear may become covered with dirt or become illegible in some other way. As a result, hazards may go unnoticed and the necessary instructions not followed. There is a risk of personal injury.

- Keep all relevant markings and inscriptions on the device in a constantly legible status.
- Immediately renew damaged, missing or incorrect nameplates or labels.

Risk of damage due to exceeding the permissible stroking range.

While manually operating with the bevel gear exceeding the actuator stroking range can cause permanent damage to the components.

- Perform the manual override maneuver operating within the actuator stroking range indicated in the actuator data sheet.
- Refer to the actuator nameplate and functioning label for fail position and direction of action.

1.3 Notes on possible property damage

⚠ NOTICE

Risk of components damage due to excessive rotation over fully retracted stem position.

The bevel gear can be damaged permanently if the stem is retracted over the limits.

- Make sure to stop rotating the handwheel when the STOP indication sticks out from the position indicator cover as per Fig. 7-3.

Risk of actuator damage due to incorrectly attached slings.

- Do not attach load-bearing slings to the handwheel or to the travel stop.

Risk of actuator damage due to the use of inappropriate tools.

Certain tools are required to work on the actuator.

- Do not use damaged tools. Refer to section 1.5.1 ‘Tools’.

Risk of actuator damage due to the use of unsuitable lubricants.

The lubricants to be used depend on the actuator material and operating temperatures. Unsuitable lubricants may corrode and damage the components.

- Use only lubricants approved by AIR TORQUE . Refer to section 1.5.3 ‘Lubricants’.

Risk of actuator damage due to excessively high or low tightening torques.

Observe the specified torques on tightening actuator components (bolts and nuts). Tightening torques above the limits lead to parts wearing out quicker. Parts that are not tightened enough may loosen.

→ Refer to section 15.2 'Tightening torques and sequences'.

1.4 Warnings on the device

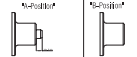
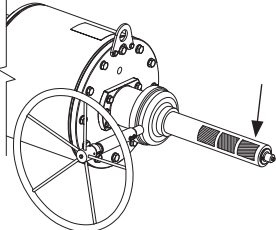
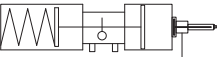
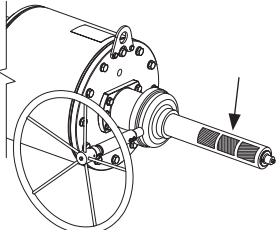

Warning label sample	Meaning of the warning	Location on the device
<p>Position indicator</p> <div data-bbox="244 629 587 786" style="border: 1px solid black; padding: 5px;"> <p>WARNING:</p> <ul style="list-style-type: none"> When using emergency operation, the indicator must be in "closed" before pressurizing the actuator. Operator's Use the indicator on Bevel Gear (BT-402) to control rotate the hand wheels in the actuator safe position. <div style="display: flex; justify-content: space-around;"> <div style="border: 1px dashed black; padding: 2px;"> <p>Bevel Gear</p>  </div> <div style="border: 1px dashed black; padding: 2px;"> <p>Local Indicator</p>  </div> </div> </div>	<p>Warning against incorrect operation exceeding the bevel gear stroke end position that can lead to components permanent damage. Refer to the position indicator for the bevel gear stroke end position limit.</p>	
<p>Functioning</p> <div data-bbox="244 913 587 1070" style="border: 1px solid black; padding: 5px;"> <p>WARNING:</p> <ul style="list-style-type: none"> Emergency manual operation must be performed only with not pressurized actuator. During normal operation, the manual override must be fully closed (unconsciously the handwheel clockwise).  <p>ET-HD14-X</p> </div>	<p>Warning against the incorrect operation of the actuator. Make sure the actuator is not pressurized while performing any operation with the bevel gear. Make sure the bevel gear is in the neutral position as per section 7.1 while operating the actuator with supply pressure.</p>	

2 Markings on the device

2.1 Nameplate

Refer to the actuator nameplate as per section 2 of the EB AT-HD mounting and operating instructions.

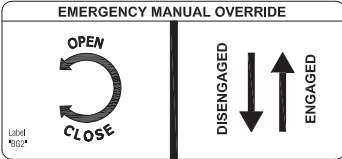
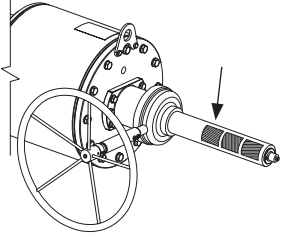
2.2 Handwheel rotation indication marking

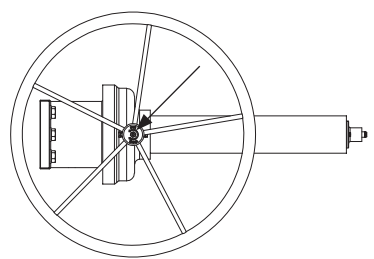
Marking samples	Content	Location on the device
	<p>Handwheel direction of rotation to drive the actuator in the close or open position. Refer to the actuator nameplate for the fail position. When the handwheel is rotated in the actuator fail direction indicated in the the marking, the bevel gear stem is retracted (refer to Section 3.1).</p>	
	<p>For declutchable bevel gear, disengaging/engaging direction of action. The engaged position is the bevel gear working position.</p>	

3 Design and principle of operation

The bevel gear for AT-HD actuators is designed to provide manual operation in case of any emergency situation, when the supply pressure is not available: the bevel gear drives the actuator and the valve in the safe position by means of a manual handwheel rotation.

3.1 Direction of action

Bevel gear for standard AT-HD scotch yoke actuators have two directions of action as per Fig. 3-1:

- STEM EXTENDING direction to compress the spring,
 - STEM RETRACTING direction to stroke the actuator in its fail direction.
- ➔ Refer to the marking (section 2) and the labels (Section 1.4) for actuator functioning in relation to the bevel gear direction of action.
- ➔ Refer to actuator nameplate for the actuator fail action and direction of rotation available options.

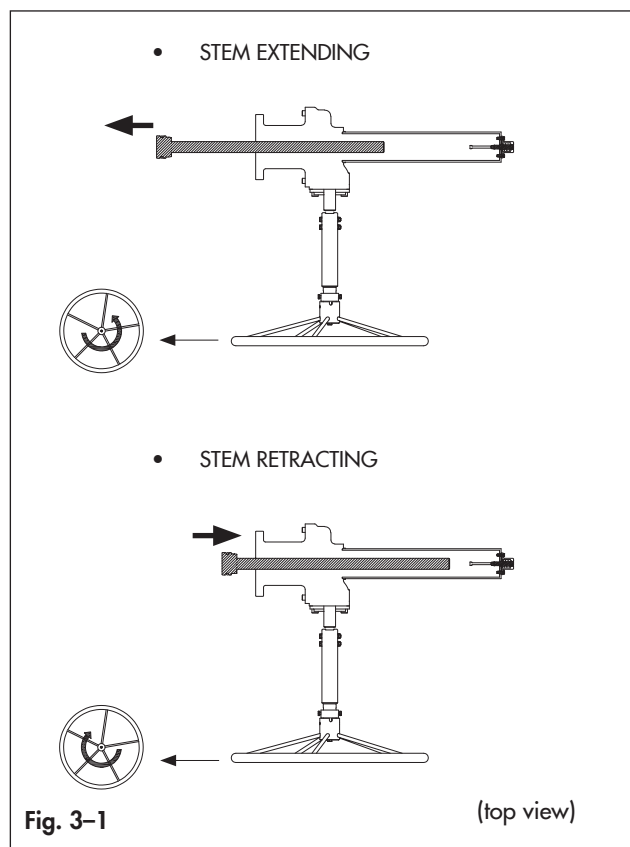

NOTICE

Risk of actuator damage due to incorrect stroke adjustment.

- Make sure that the actuator and the manual override are correctly oriented, with reference to the rotation direction required.
- Make sure that the stroke of the manual override does not exceed the stroke allowed by the actuator.

3.2 Versions

The bevel gear is available in two version:

1. with declutchable handwheel
2. with non declutchable handwheel.

3.2.1 Declutchable handwheel

The declutchable handwheel has two positions.

- Disengaged position that is the resting position where the bevel gear cannot be operated.
- Engaged position that is the temporary working position reached pushing the handwheel as per Fig. 3-2 where the bevel gear can be operated. Once the pushing force applied to the handwheel is interrupted, the handwheel returns in its disengaged position.

Note

A padlock is available on request to permanently block the declutchable handwheel in the disengaged or engaged position in order to avoid any bevel gear accidental operation.

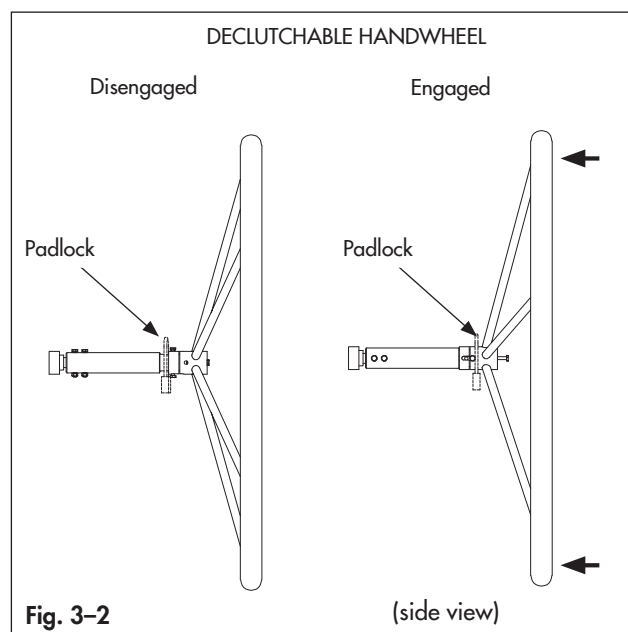

3.2.2 Non declutchable handwheel

The handwheel is permanently engaged so the bevel gear can be operated at any moment.

3.3 Technical data

Refer to the bevel gear technical data sheet for dimensions and configurations available.

Operating temperature

The actuator nameplate provides indication on the bevel gear operating temperatures.

- “S” for standard temperatures from -40°C (-40°F) to +80°C (+176°F).

Design and principle of operation

- "H" for high temperatures from -15°C (+5°F) to +150°C (+302°F).
 - "L" for extremely low temperatures from -60°C (-76°F) to +80°C (+176°F).
- Refer to the data sheet HD50900E for the soft spare parts material.
- Refer to section 15.3 for the lubricant type in relation to the different working temperature ranges.

4 Shipment and on-site transport

The work described in this section is only to be performed by fully trained and qualified personnel.

4.1 Accepting the delivered goods

→ Refer to the EB AT-HD mounting and operating instructions (section 4).

4.2 Removing the packaging from the actuator with bevel gear

→ Refer to the EB AT-HD mounting and operating instructions (section 4).

4.3 Transporting and lifting the actuator with bevel gear

→ Refer to the EB AT-HD mounting and operating instructions for transporting and lifting indications and safety notes.

NOTICE

Risk of actuator damage due to incorrectly attached slings.

Only attach load slings to vertically lift the actuator on its own. The lifting points must not be used to lift the entire actuator and valve assembly.

- Do not attach load-bearing slings to the complementary or accessory components.
- Do not attach load-bearing slings to the handwheel.
- Do not use damaged or defective slings.
- Do not shorten the slings with knots or bolts or other makeshift devices.
- Observe lifting instructions (see section 4.3.2).

Tip

Our aftersales service (aftersales@airtorque.it) can provide more detailed transport and lifting instructions on request.

4.3.1 Transporting the actuator with bevel gear

→ Refer to the EB AT-HD mounting and operating instructions (section 4).

4.3.2 Lifting the actuator with bevel gear

→ Refer to the EB AT-HD mounting and operating instructions (section 4).

Lifting instructions

→ Refer to the EB AT-HD mounting and operating instructions (section 4) for actuator with bevel gear lifting instructions.

While servicing the bevel gear:

- Use appropriate tackles and slings to lift the bevel gear.
- Use choker hitch to provide better load control.
- Do not attach any sling to the cover (BW04). (Fig. 4-1)

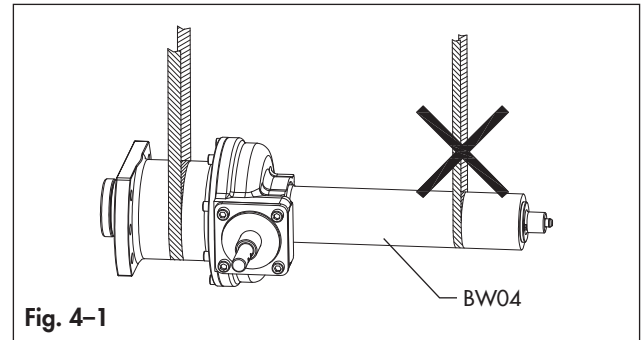

Fig. 4-1

- Remove the handwheel before lifting the bevel gear as per Fig. 4-1.
- Refer to section 10 for handwheel removal.
- Refer to section 5 for handwheel reassembly over the bevel gear.
- Do not drill extra holes into the bevel gear.
- Do not use the actuator with bevel gear lifting points to lift the entire actuator and valve assembly. (Fig. 4-2)
- Refer to the warning labels over the actuator (section 1.4)

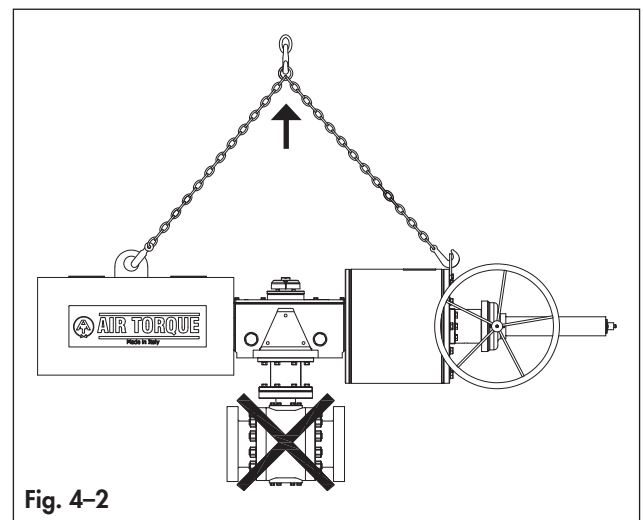

Fig. 4-2

4.4 Storing the actuator with bevel gear

NOTICE

Risk of damage due to improper storage.

- Observe the storage instructions.
- Observe the rubber components storage instructions (T 3.3.3.1 EN).
- Avoid long storage times. Contact AIR TORQUE in case of different storage conditions or long storage periods.

Note

We recommend regularly checking the bevel gear and the prevailing storage conditions during long storage times.

Shipment and on-site transport

Storage instructions

- Refer to the EB AT-HD mounting and operating instructions (section 4).

5 Mounting and assembly

The work described in this section is only to be performed by fully trained and qualified personnel.

5.1 Preparation for installation

- Refer to the EB AT-HD mounting and operating instructions (section 5).

5.2 Mounting the actuator with bevel gear over the valve

- Refer to the EB AT-HD mounting and operating instructions (section 5).

6 Start-up

The work described in this section is only to be performed by fully trained and qualified personnel.

⚠ WARNING

Risk of bursting in the actuator

Pneumatic actuators with bevel gear are pressure equipment that may burst when handled incorrectly. Flying projectile fragments or components can cause serious injury or even death.

- ➔ Before mounting the bevel gear over the actuator disconnect all pneumatic / hydraulic / electrical supplies and discharge the pressure from the actuator.

⚠ WARNING

Crush hazard arising from moving parts.

The actuator and the valve assembly contains moving parts, which can injure hands or fingers.

- ➔ Do not touch or insert hands or finger into moving parts.
- ➔ Before starting any work on the actuator disconnect all pneumatic / hydraulic / electrical supplies and discharge the pressure from the actuator.

In case of a declutchable handwheel make sure to remove or set the padlock, if any, in the correct position as per Fig. 6-1.

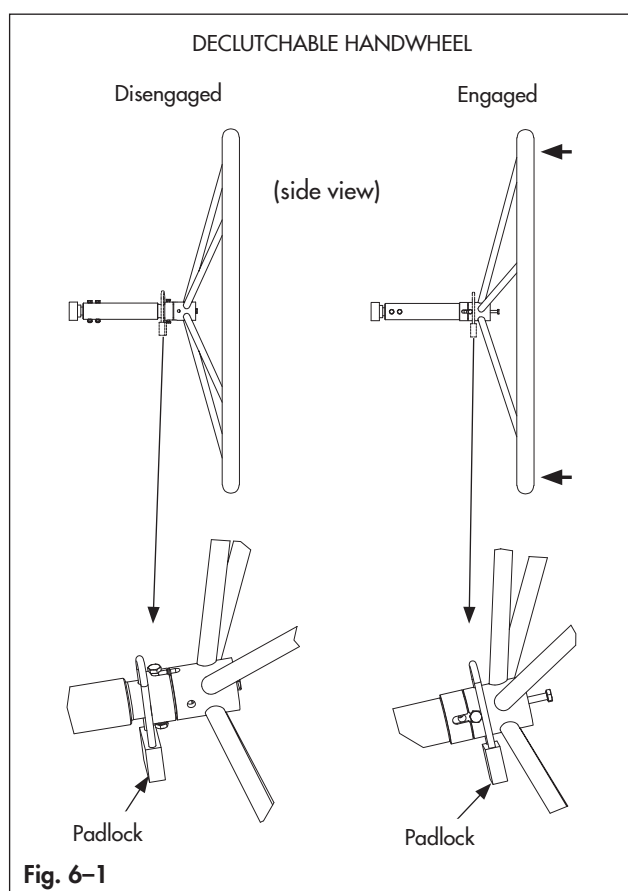

i Note

Make sure to correctly store the padlock key in order to have it available when required.

7 Operation

The work described in this section is only to be performed by fully trained and qualified personnel.

⚠ WARNING

Crush hazard arising from moving parts.

The actuator and the valve assembly contains moving parts, which can injure hands or fingers.

- ➔ Do not touch or insert hands or finger into moving parts.
- ➔ Before starting any work on the bevel gear disconnect all pneumatic/hydraulic/electrical supplies and discharge the pressure from the actuator.
- ➔ Do not impede the movement of the yoke by inserting objects into the actuator.

⚠ WARNING

Risk of personal injury through incorrect operation, use or installation as a result of information on the actuator being illegible.

Over time, markings, labels and nameplates on the actuator may become covered with dirt or become illegible in some other way. As a result, hazards may go unnoticed and the necessary instructions not followed. There is a risk of personal injury.

- ➔ Keep all relevant markings and inscriptions on the device in a constantly legible state.
- ➔ Immediately renew damaged, missing or incorrect nameplates or labels.

7.1 Bevel gear neutral position

⚠ WARNING

Risk of bursting in the actuator.

Pneumatic actuators with bevel gear are pressure equipment that may burst when handled incorrectly. Flying projectile fragments or components can cause serious injury or even death.

- ➔ Before mounting the bevel gear over the actuator disconnect all pneumatic / hydraulic / electrical supplies and discharge the pressure from the actuator.

ⓘ NOTICE

Risk of components damage due to excessive force applied to the handwheel.

Permanent damage can occur in case the bevel gear is stressed over the limits.

- ➔ The maximum operating force that can be applied to the handwheel is 400 N.
- ➔ Make sure the padlock has been removed or it is in the correct position as per section 6.

- From the starting position (Fig. 7-1) slowly rotate the handwheel extending the stem to reach a little rotation (max. 5°) of the position indicator. (Fig. 7-2)

- ➔ The manual force needed to rotate the handwheel is high at this point.

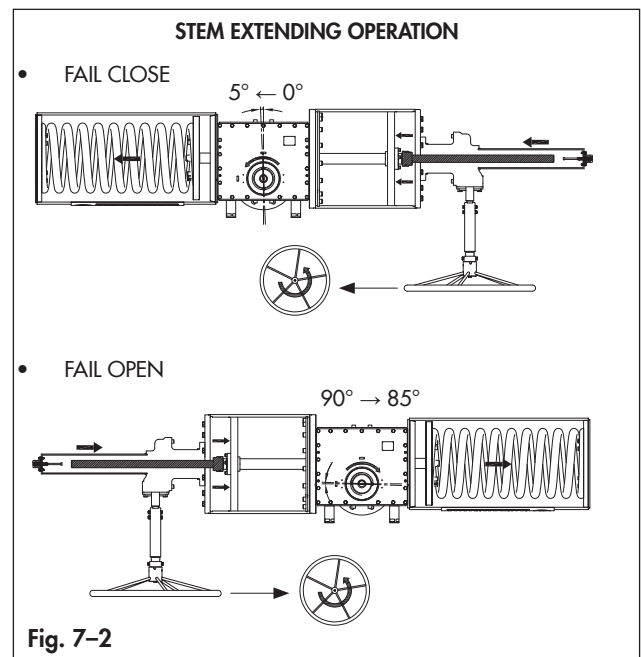
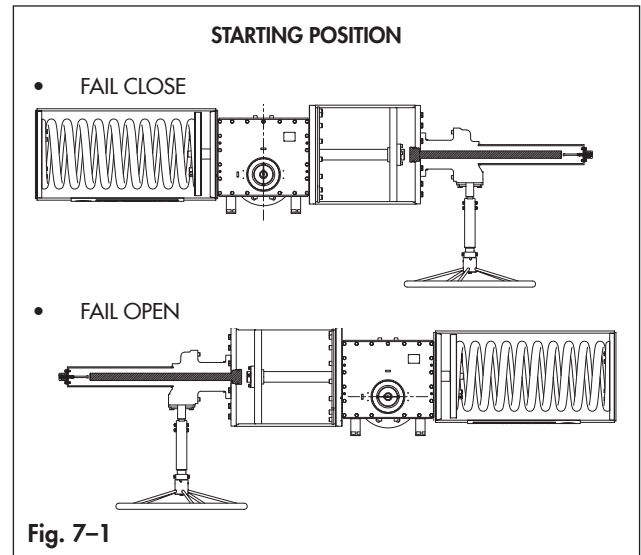

- Rotate the handwheel in the opposite direction (retracting the stem) discharging the load when the bevel gear stem is detached from the loaded parts of the actuator. (Fig. 7-3)

- ➔ The manual force needed to rotate the handwheel after detaching will drop almost to zero.

ⓘ NOTICE

Risk of components damage due to excessive rotation over fully retracted stem position.

The bevel gear can be damaged permanently if the stem is retracted over the limits.

- ➔ Make sure to stop rotating the handwheel when the STOP indication sticks out from the position indicator cover as per Fig. 7-3.

Operation

- Continue rotating the handwheel in same direction (retracting the stem) for few more turns until the position indicator sticks out.
- ➔ At this point the bevel gear has reached the NEUTRAL POSITION.

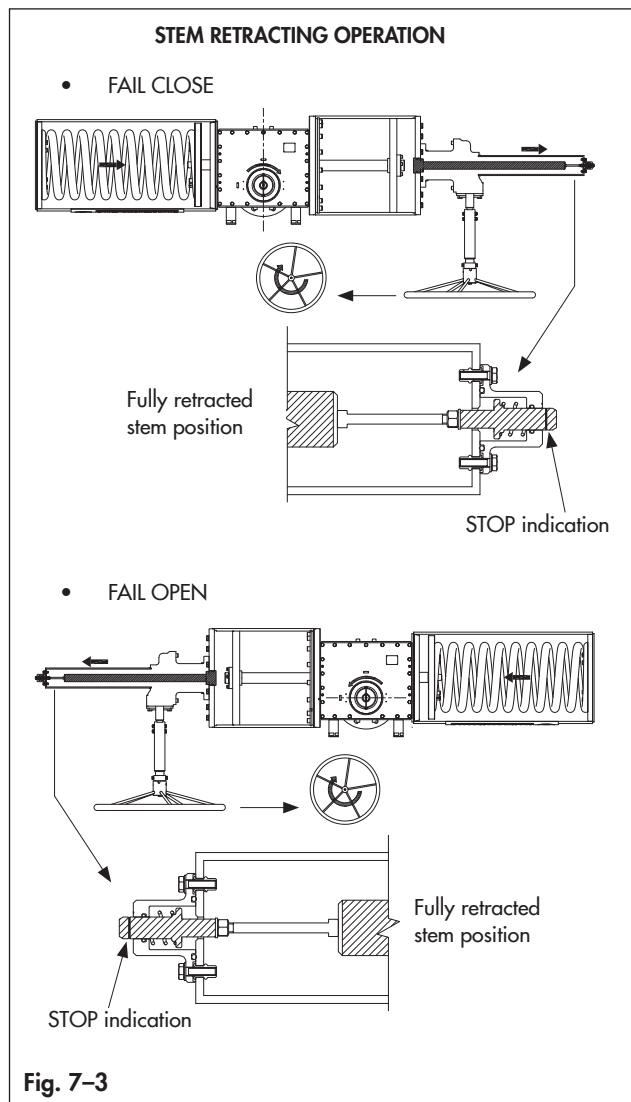

7.2 Actuator operated with supply pressure

⚠ WARNING

Risk of damage due to incorrect positioning of the bevel gear.

The bevel gear must be in the NEUTRAL POSITION while operating the actuator with supply pressure.

- ➔ Refer to section 7.1 to set the bevel gear in the neutral position.

⚠ WARNING

Risk of damage due to accidental operation of the bevel gear.

The non declutchable handwheel is permanently engaged in the working position.

The declutchable handwheel blocked in engaged position with the padlock is permanently in working position. Any accidental rotation can lead to components damage.

- ➔ Make sure the declutchable handwheel is blocked with the padlock, if any, in the correct position as per section 6.
- ➔ Make sure the key is properly stored in order to have it available when required.

Refer to the EB AT-HD mounting and operating instructions for the correct actuator operation indications.

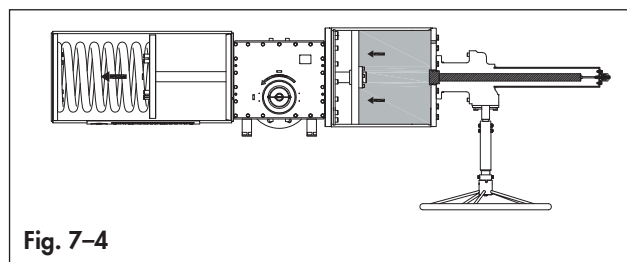

7.3 Manual operation with bevel gear

⚠ WARNING

Risk of damage due to incorrect positioning of the bevel gear.

The bevel gear must be in the NEUTRAL POSITION before starting manual operation.

- ➔ Refer to section 7.1 to set the bevel gear in the neutral position.

⚠ WARNING

Risk of bursting in the actuator.

Pneumatic actuators are pressure equipment that may burst when handled incorrectly. Flying projectile fragments or components can cause serious injury or even death.

- ➔ Before manually operating the bevel gear disconnect all pneumatic / hydraulic / electrical supplies and discharge the pressure from the actuator.

⚠ WARNING

Risk of damage due to stroking range violation.

While manually operating with the bevel gear exceeding the actuator stroking range can cause permanent damage to the components.

- ➔ Perform the manual override maneuver operating within the actuator stroking range indicated in the actuator data sheet.
- ➔ Refer to the actuator nameplate and functioning label for fail position and direction of action.

NOTICE

Risk of components damage due to excessive force applied to the handwheel.

Permanent damage can occur in case the bevel gear is stressed over the limits.

- ➔ The maximum operating force that can be applied to the handwheel is 400 N.
- ➔ Make sure the padlock has been removed or it is in the correct position as per section 6.

NOTICE

Risk of handwheel damage due to the use of unsuitable tools.

- ➔ Do not use any additional tools to turn the handwheel, such as a lever or a wrench.

- Rotate the handwheel extending the stem to compress the actuator spring.
- ➔ Refer to the actuator nameplate and functioning label for fail position, direction of action and stroke range.
- Rotate the handwheel retracting the stem releasing the spring compression stroking the actuator back in the fail position. (Fig. 7-5 and Fig. 7-6)

After manually operating, decommission the bevel gear setting it in the neutral position (section 7.1).

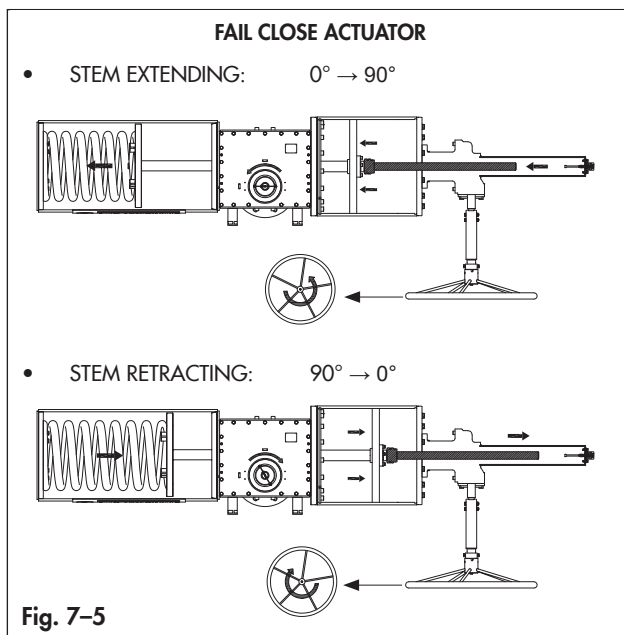
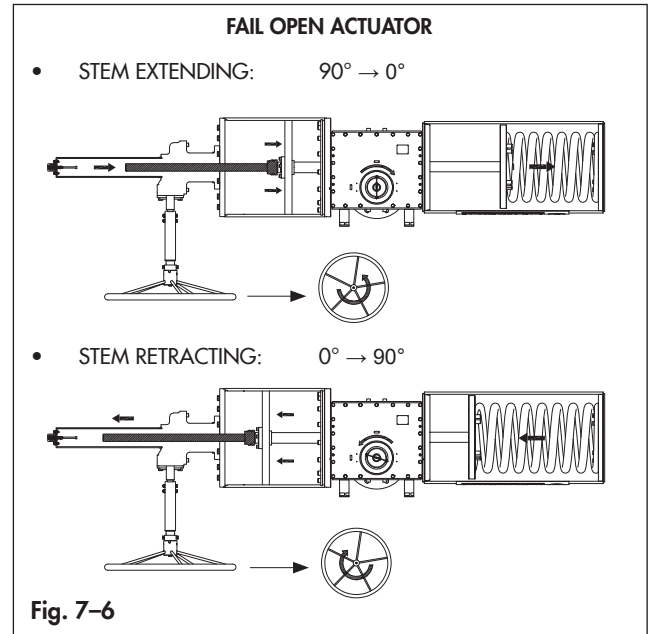

8 Malfunctions

The work described in this section is only to be performed by fully trained and qualified personnel.

8.1 Troubleshooting

→ Refer to the EB AT-HD mounting and operating instructions for actuator troubleshooting.

Malfunction	Possible reasons	Reccomended action
Difficult manual operation	Actuator is pressurised	Discharge the actuator before manual operation
	Blocked Actuator	Check the actuator documentation.
	Blocked Valve	Check the valve documentation and contact the manufacturer
Incomplete rotation	Incorrect stroke adjustment	Observe indications in section 7.1 for correct stroke adjustment
	Foreign object left inside the actuator	Check the actuator documentation.
	Faulty valve	Check the valve documentation and contact the manufacturer

i Note

Contact AIR TORQUE (aftersales@airtorque.it) for malfunctions not listed in the table.

8.2 Emergency action

The plant operator is responsible for emergency action to be taken in the plant.

9 Service

The work described in this section is only to be performed by fully trained and qualified personnel.

Before service make sure:

- to decommission (section 10) the actuator and the bevel gear.
- to remove the actuator with bevel gear from the valve as per section 11.

⚠ DANGER

Risk of bursting in the actuator

Pneumatic actuators with bevel gear are pressure equipment that may burst when handled incorrectly. Flying projectile fragments or components can cause serious injury or even death.

- ➔ *Before starting any work on the actuator with bevel gear disconnect all pneumatic / hydraulic / electrical supplies and discharge the pressure from the actuator.*

⚠ WARNING

Crush hazard arising from moving parts.

The actuator and the valve assembly contains moving parts, which can injure hands or fingers.

- ➔ *Do not touch or insert hands or finger into moving parts.*
- ➔ *Before starting any work on the actuator disconnect all pneumatic / hydraulic / electrical supplies and discharge the pressure from the actuator.*
- ➔ *Do not impede the movement of the yoke by inserting objects into the actuator.*

📌 NOTICE

Risk of bevel gear damage due to excessively high or low tightening torques.

Observe the specified torques on tightening actuator components (bolts and nuts). Tightening torques above the limits lead to parts wearing out quicker. Parts that are not tightened enough may loosen.

- ➔ *Observe the specified tightening torques in section 15.2.*

i Note

- *The product warranty becomes void if service or repair work not described in these instructions is performed without prior agreement by AIR TORQUE's After-sales Service.*
- *Only use original spare parts by AIR TORQUE, which comply with the original specifications.*

With the information given below, AIR TORQUE provides the end user with all the required information necessary for service.

Under normal conditions, the bevel gear requires only periodic observation to ensure proper operation. However, due to critical working conditions and a natural components ageing effect even if properly stored, a preventive service program is essential to ensure good performance, safe operation and an

extended life of the actuator. AIR TORQUE recommend to perform the bevel gear service when servicing the actuator.

- ➔ Refer to the EB AT-HD mounting and operating instruction for actuator service timing (section 9).
- ➔ Spare kits are available for seals and bearing replacement as per data sheet HD50900E.
- ➔ Refer to the Rubber products storage instructions (T3.3.3.1 EN).

9.1 Preparation for servicing

1. Lay out the necessary material and tools to have them ready for the intended work.
2. Put the actuator out of operation (see the 'Decommissioning' section).
3. Remove the actuator from the valve (see the 'Removal' section).

9.2 Disassembly

⚠ DANGER

Risk of bursting in the actuator

Pneumatic actuators with bevel gear are pressure equipment that may burst when handled incorrectly. Flying projectile fragments or components can cause serious injury or even death.

- ➔ *Before disassembling the bevel gear from the actuator disconnect all pneumatic / hydraulic / electrical supplies and discharge the pressure from the actuator.*

📌 NOTICE

Risk of components damage due to incorrect storage.

Store the single components in a clean and safe area once disassembled, before proceeding with the service and the reassembly.

Proceed as follows to remove the bevel gear from the actuator:

- Disconnect any electrical/pneumatic/hydraulic power supply from the actuator and make sure the actuator itself is depressurized.
- Disconnect all electrical wirings of the control or signal devices, if any.
- ➔ Refer to the control or signal devices documentation for safe disassembly.
- Make sure the actuator is in its fail safe position.
- ➔ Refer to the actuator nameplate.
- Make sure the bevel gear is in the neutral position.
- ➔ Refer to section 7.1.
- Remove the handwheel from the bevel gear unscrewing the bolts (BW19) and nuts (BW21) along with the washers (BW22). (Fig. 9-1)

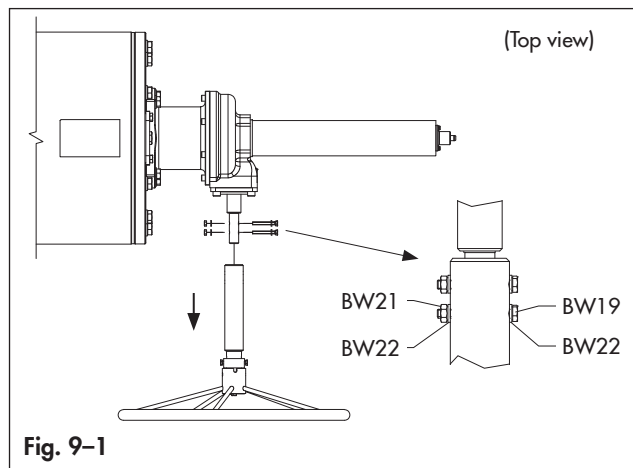

Fig. 9-1

- Support the bevel gear with proper lifting equipment.
- ➔ Refer to section 4.
- Unscrew the bolts (BW12) following the sequence as per Fig. 9-2 and carefully remove the bevel gear from the actuator making sure not to damage the o-ring (BW08).
- ➔ Refer to section 15 for tightening torque values.
- Make sure the pins (BW17) are still correctly in position over the actuator.
- Place the bevel gear over a safe and clean workbench.

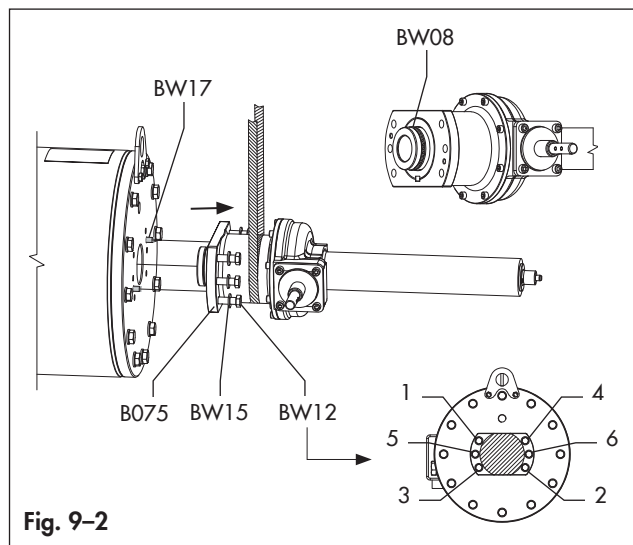

Fig. 9-2

- Remove the o-ring (BW08) from the bevel gear. (Fig. 9-3)

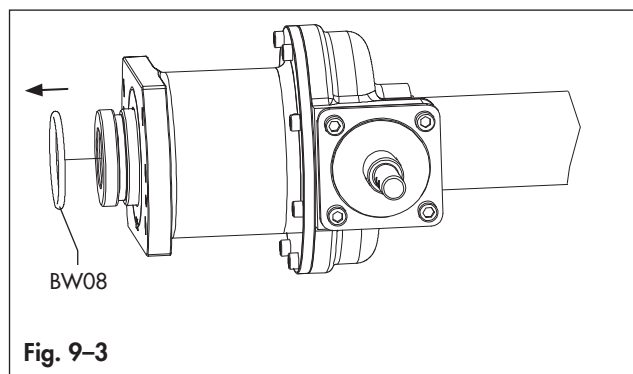

Fig. 9-3

9.3 Service operations

- Inspect and clean every single component.
- Inspect, clean and replace bolts and nuts, if needed.
- Discard and replace the damaged soft components available in the spare parts kit.
- ➔ Refer to the spare parts kit data sheet HD50900E and to the Rubber products storage instructions T 3.3.3.1 EN.
- Clean and lubricate every o-ring housing.
- Lubricate every o-ring during reassembling.
- ➔ Refer to the data sheet HD50900E for the correct lubricant type.
- Clean and lubricate every sliding component and its housing.
- ➔ Refer to the section 15.3 'Lubricants'.
- Where required during the reassembly apply the correct threadlocker.
- ➔ Refer to the threadlocker types indicated in section 15.4.

9.4 Reassembly

NOTICE

Risk of actuator damage due to the use of unsuitable lubricants.

The lubricants to be used depend on the actuator material and operating temperatures. Unsuitable lubricants may corrode and damage the surface.

➔ Only use lubricants approved by AIR TORQUE indicated in section 15.3.

- Lubricate and place the o-ring (BW08) in its housing. (Fig. 9-4)

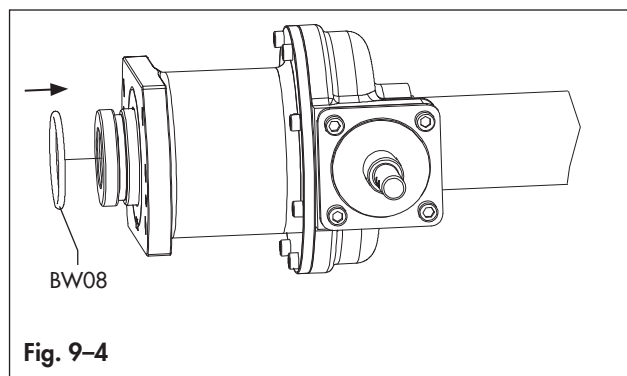
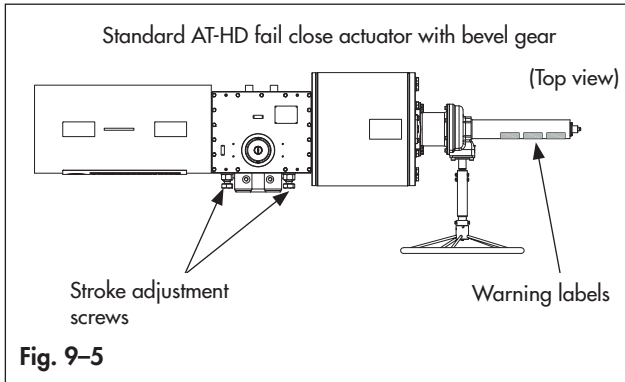

Fig. 9-4

9.4.1 Mounting the bevel gear over the actuator

- Before fitting the bevel gear over the actuator, make sure that they are correctly oriented, with reference to warning label over the bevel gear. (Fig. 9-5)



Refer to Fig. 9-6 and proceed as follows to mount the bevel gear over the actuator:

- Disconnect any electrical/pneumatic/hydraulic power supply to the actuator.
- Make sure the actuator is in its fail safe position.
- ➔ Refer to the actuator nameplate.
- Clean the bevel gear and the actuator interface to remove completely any external body or dirt.

⚠ WARNING

Risk due to suspended components falling.
 Suspended components may fall and cause serious injuries if not properly handled.
 ➔ Use proper lifting and supporting equipment.

- Lift and align the bevel gear to the actuator as per Fig. 9-6 with proper equipment.
- Carefully engage the flange (B075) into the pins (BW17) making sure not to damage the o-ring (BW08).
- Apply the threadlocker Loxeal 83•21 or equivalent on the screws (BW12).
- Fix the bevel gear over the actuator fastening the screws (BW12) along with the washers (BW15) at the correct tightening torques (section 15) and following the sequence as per Fig. 9-6.

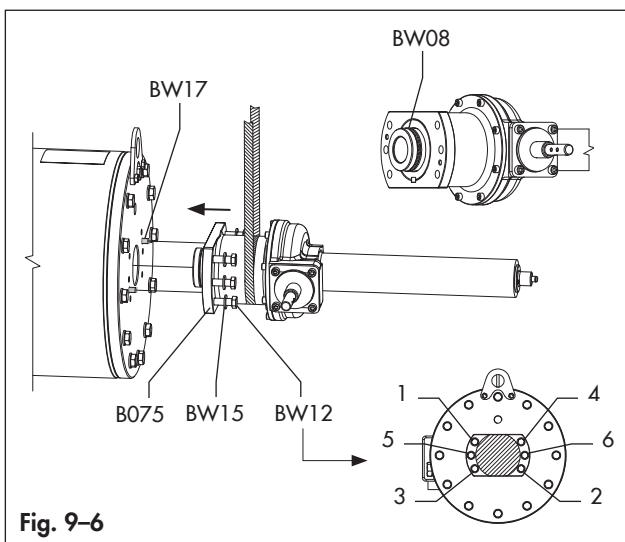

- Place the handwheel over the bevel gear and fix it in position fastening the bolts (BW19) and nuts (BW21) along with the washers (BW22) after applying the threadlocker Loxeal 83•21 or equivalent. (Fig. 9-7)

➔ Refer to section 15 for the correct tightening torque

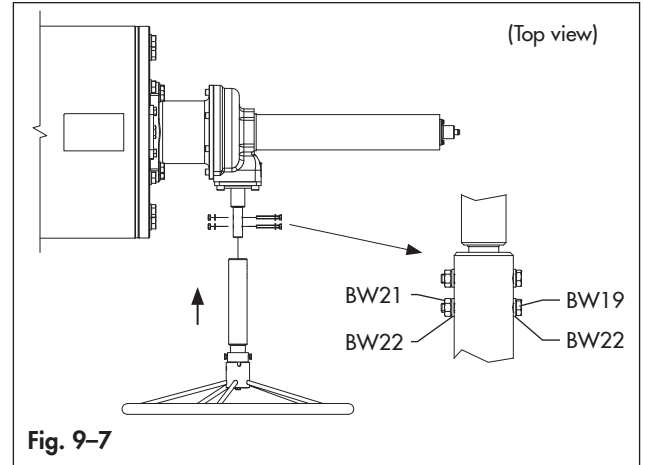

10 Decommissioning

The work described in this section is only to be performed by fully trained and qualified personnel.

⚠ DANGER

Risk of bursting due to incorrect opening of pressurized equipment or components.

Pneumatic actuators are pressure equipment that may burst when handled incorrectly. Flying projectile fragments or components can cause serious injury or even death.

→ *Before starting any work on the actuator with bevel gear disconnect all pneumatic/hydraulic/electrical supplies and discharge the pressure from the actuator.*

⚠ WARNING

Crush hazard arising from moving parts.

The actuator with bevel gear and the valve assembly contains moving parts, which can injure hands or fingers.

→ *Do not touch or insert hands or finger into moving parts.*

→ *Before starting any work on the bevel gear disconnect all pneumatic/hydraulic/electrical supplies and discharge the pressure from the actuator.*

To decommission the bevel gear for service work or before removing it from the actuator, proceed as follows:

1. Put the valve and its accessories out of operation in a safe position. Refer to the documentation available from the valve manufacturer.
2. Decommission the actuator as per section 10 of the EB AT-HD mounting and operating instructions.
3. Decommission the bevel gear setting it in a neutral position as per section 7.1.

11 Removal

The work described in this section is only to be performed by fully trained and qualified personnel.

Before removing from the valve, make sure the actuator and the bevel gear are put out of operation.

→ Refer to section 10 'Decommissioning'.

To remove the actuator with bevel gear from the valve refer to the EB AT-HD mounting and operating instructions (section 11).

12 Repairs

If the actuator with bevel gear does not function properly according to how it was originally sized or does not function at all, it is defective and must be repaired or replaced.

ⓘ NOTICE

Risk of components damage due to incorrect repair work.

- *Do not perform any repair work on your own.*
 - *Contact AIR TORQUE (aftersales@airtorque.it) for repair work.*
-

13 Disposal

At the end of their life cycle AIR TORQUE bevel gears can be disassembled and disposed sorting the components by the different materials.

- Observe local, national and international refuse regulations.

All materials have been selected in order to ensure minimal environmental impact, health and safety of personnel during their installation and maintenance, provided that, during use, they are not contaminated by hazardous substances.

Oil, grease and electric components may require special treatment before disposal.

- Contact waste management companies and/or local authorities.
- The disposal is to be performed by fully trained and qualified personnel only.
- Decommission and remove the bevel gear (section 10 and section 11).
- Create a large area around the bevel gear in order to work in safe conditions without obstacles that can interfere with the disposal operation.
- Dismantle the bevel gear sorting the components by the different materials.

14 Certificates

- Refer to EB AT-HD mounting and operating instructions (section 14) for actuator certificates and documents available from AIR TORQUE.

15 Annex

15.1 Tools

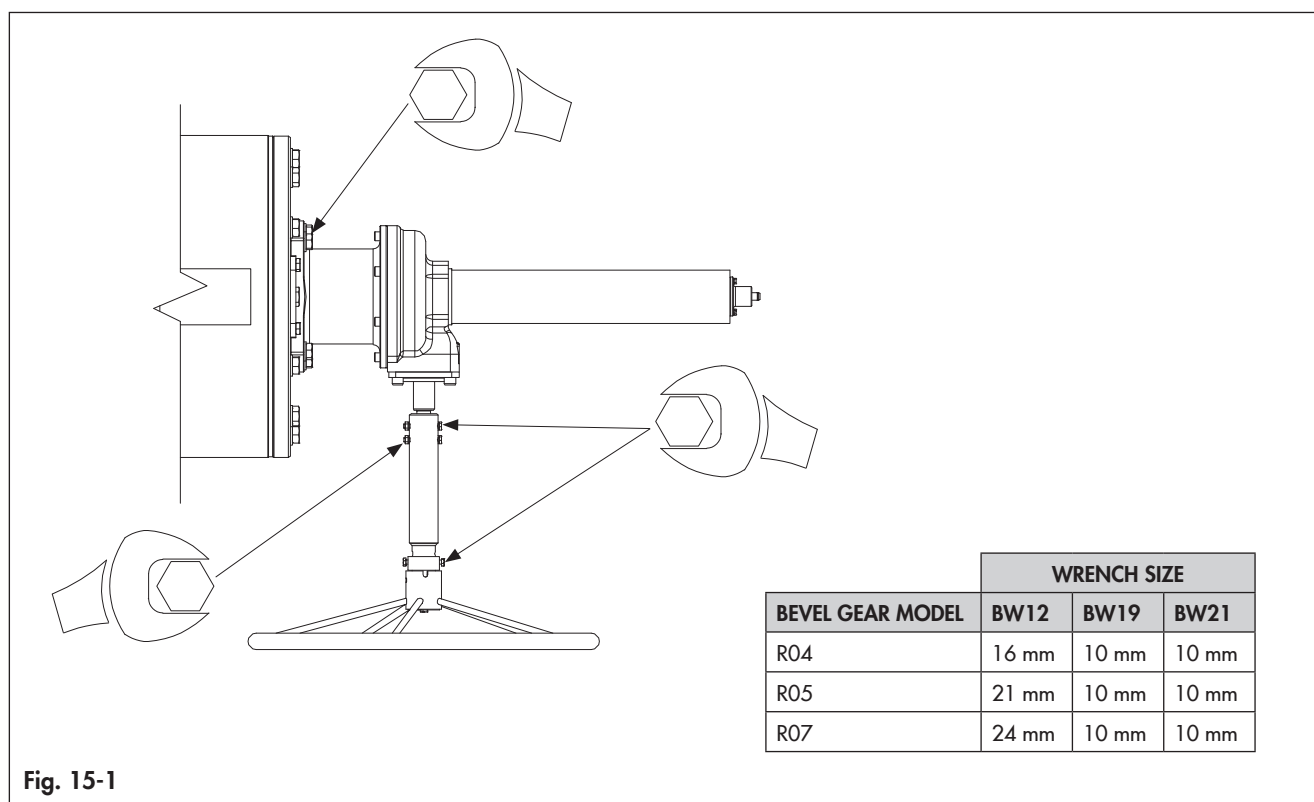

Fig. 15-1

15.2 Tightening torques and sequences

- All the tightening torques are intended in Nm.
- Tightening torque tolerance: $\pm 10\%$.
- The tightening torques are based on a friction coefficient of 0.12 with a lubricated fixing elements (bolts or nuts) threads.
- After long operating times or use at temperatures above 80°C , the breakaway torque may be significantly higher.

Table 15-1: Tightening torques

BEVEL GEAR MODEL	SCREW	THREAD	TORQUE [Nm]
R04	BW12	M10	25 ÷ 30
	BW19	M6	7 ÷ 8
R05	BW12	M14	55 ÷ 60
	BW19	M6	7 ÷ 8
R07	BW12	M16	100 ÷ 105
	BW19	M6	7 ÷ 8

15.3 Lubricants

The AT-HD actuators are factory lubricated for the life of the actuator in normal working conditions.

→ Refer to the data sheet HD50900E for lubricant type in relation to the different working temperature ranges.

15.4 Threadlocker

The recommended threadlocker types for AT-HD the actuators are:

- Loxeal 83•21 or equivalent.



AIR TORQUE

AIR TORQUE S.P.A.

Via dei Livelli di Sopra 11 · 24060 Costa di Mezzate (BG), Italy

Phone: +39 035 682299 · Fax: +39 035 687791

info@airtorque.it · www.airtorque.it