

Original instructions

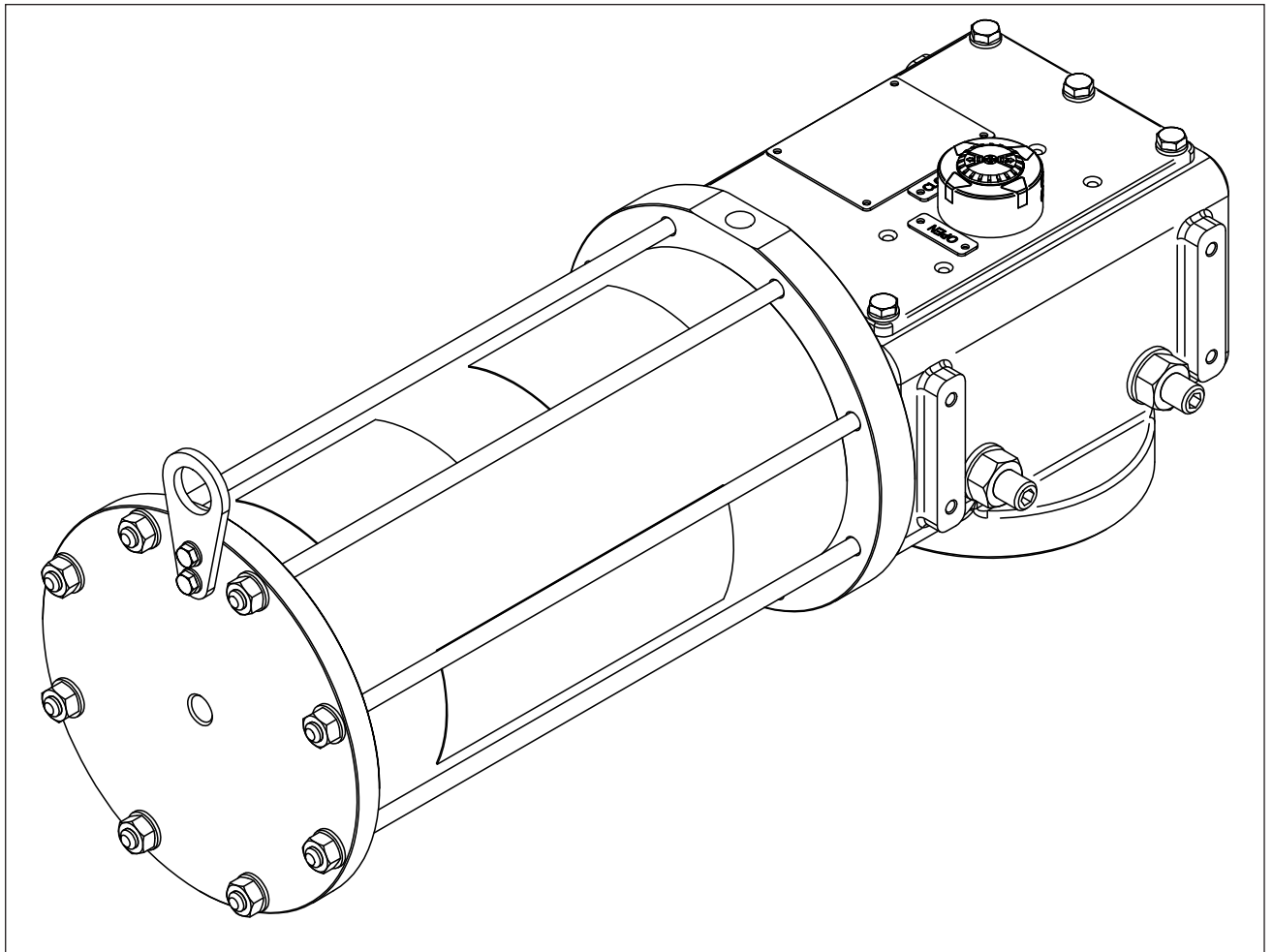

AT-HDC series

Compact scotch yoke pneumatic actuators

Note on these mounting and operating instructions

These mounting and operating instructions assist you in mounting and operating the device safely. The instructions are binding for handling AIR TORQUE devices. The images shown in these instructions are for illustration purposes only. The actual product may vary.

- For the safe and proper use of these instructions, read them carefully and keep them for later reference.
- If you have any questions about these instructions, contact AIR TORQUE's After-sales Service Department (aftersales@airtorque.it).



The mounting and operating instructions for the devices are included in the scope of delivery. The latest documentation is available on our website at www.airtorque.it

Definition of signal words

DANGER

Hazardous situations which, if not avoided, will result in death or serious injury

WARNING

Hazardous situations which, if not avoided, could result in death or serious injury

NOTICE

Property damage message or malfunction

Note

Additional information

Tip

Recommended action

1	Safety instructions and measures	1-1
1.1	Notes on possible severe personal injury	1-2
1.2	Notes on possible personal injury	1-2
1.3	Notes on possible property damage	1-2
1.4	Warnings on the device	1-3
2	Markings on the device	2-1
2.1	Actuator nameplate	2-1
2.1.1	Standard nameplate sample	2-1
2.1.2	PED marked nameplate sample	2-3
2.2	Functioning label sample	2-4
3	Design and principle of operation	3-1
3.1	Direction of action and fail position	3-1
3.2	Complementary parts	3-1
3.3	Technical data	3-2
4	Shipment and on-site transport	4-1
4.1	Accepting the delivered goods	4-1
4.2	Removing the packaging from the actuator	4-1
4.3	Transporting and lifting the actuator	4-1
4.3.1	Transporting the actuator	4-1
4.3.2	Lifting the actuator	4-1
4.4	Storing the actuator	4-2
5	Mounting and assembly	5-1
5.1	Preparation for installation	5-1
5.2	Control and signal devices assembly	5-1
5.3	Mounting the actuator over the valve	5-1
6	Start-up	6-1
7	Operation	7-1
8	Malfunctions	8-1
8.1	Troubleshooting	8-1
8.2	Emergency action	8-1
9	Service	9-1
9.1	Preparation for servicing	9-2
9.2	Part List	9-2
9.3	Disassembly	9-3
9.3.1	Stroke adjustment screws removal	9-3
9.3.2	(W) Welded central module configuration disassembly	9-3
9.3.2.1	Cover removal	9-3
9.3.2.2	Central module disassembly	9-3
9.3.3	(C) Casted central module configuration disassembly	9-6
9.3.3.1	Cover removal	9-6
9.3.3.2	Central module disassembly	9-6
9.3.4	Power module disassembly	9-9
9.3.5	Piston disassembly	9-9
9.4	Service operations	9-10
9.5	Reassembly	9-10
9.4.1	Piston reassembly	9-10
9.4.2	Power module reassembly	9-11
9.4.3	(W) Welded central module configuration reassembly	9-12
9.4.3.1	Central module reassembly	9-12
9.4.3.2	Cover reassembly	9-14
9.4.4	(C) Casted central module configuration reassembly	9-15
9.4.4.1	Central module reassembly	9-15
9.4.4.2	Cover reassembly	9-17
9.4.5	Stroke adjustment screws reassembly	9-17
9.4.6	Stroke adjustment	9-17
9.4.7	Mounting the actuator over the valve	9-17

10	Decommissioning	10-1
11	Removal	11-1
12	Repairs	12-1
13	Disposal	13-1
14	Certificates	14-1
15	Annex	15-1
15.1	Tools	15-1
15.2	Tightening torques and sequences	15-2
15.3	Lubricants	15-4
15.4	Threadlocker	15-4

1 Safety instructions and measures

Intended use

The AIR TORQUE AT-HDC Series actuators are intended for the automation and operation of quarter-turn valves such as butterfly valves, ball valves and plug valves in both indoor and outdoor applications. Depending on the configuration, the actuator is suitable for on/off or modulating duties. The actuator can be used in processing and industrial plants.

The actuator is designed to operate under exactly defined conditions (e.g. temperature, pressure, travel). Therefore, operators must ensure that the actuator is only used in operating conditions that meet the specifications used for sizing the actuator at the ordering stage. In case operators intend to use the actuator in other applications or conditions than specified, contact AIR TORQUE.

AIR TORQUE does not assume any liability for damage resulting from the failure to use the device for its intended purpose or for damage caused by external forces or any other external factors.

- ➔ Refer to the technical data and nameplate for limits and fields of application as well as possible uses.

This manual is intended to be used with standard AT-HDC Series actuators, for special configurations please contact AIR TORQUE.

Reasonably foreseeable misuse

The actuator is not suitable for the following applications:

- Use outside the limits defined during sizing and by the technical data
- Use outside the limits defined by the accessories connected to the actuator

Furthermore, the following activities do not comply with the intended use:

- Use of non-original spare parts
- Performing service and repair work not described in these instructions

Qualifications of operating personnel

The actuator must be mounted, started up, serviced and repaired by fully trained and qualified personnel only; the accepted industry codes and practices are to be observed. According to these mounting and operating instructions, trained personnel refers to individuals who are able to judge the work they are assigned to and recognize possible hazards due to their specialized training, their knowledge and experience as well as their knowledge of the applicable standards.

Personal protective equipment

We recommend wearing the following personal protective equipment when handling the AIR TORQUE actuators:

- Protective gloves and safety footwear when mounting or removing the actuator
- Eye protection and hearing protection while the actuator is operating.

- ➔ Check with the plant operator for details on further protective equipment.

Revisions and other modifications

Revisions, conversions or other modifications of the product are not authorized by AIR TORQUE. They are performed at the user's own risk and may lead to safety hazards, for example. Furthermore, the product may no longer meet the requirements for its intended use.

Safety devices

The AIR TORQUE actuators alone do not have any special safety equipment.

Warning against residual hazards

To avoid personal injury or property damage, plant operators and operating personnel must prevent hazards that could be caused in the actuator by the signal pressure, stored spring energy or moving parts by taking appropriate precautions. They must observe all hazard statements, warning and caution notes in these mounting and operating instructions.

Responsibilities of the operator

The operator is responsible for proper operation and compliance with the safety regulations. Operators are obliged to provide these mounting and operating instructions as well as the referenced documents to the operating personnel and to instruct them in proper operation.

Furthermore, the operator must ensure that operating personnel or third persons are not exposed to any danger.

These instructions should not supersede or replace any customer's plant safety or work procedures. If a conflict arises between these instructions and the customer's procedures, the differences should be resolved in writing between an authorized customer's representative and an authorized AIR TORQUE representative.

Responsibilities of operating personnel

Operating personnel must read and understand these mounting and operating instructions as well as the referenced documents and observe the specified hazard statements, warnings and caution notes. Furthermore, the operating personnel must be familiar with the applicable health, safety and accident prevention regulations and comply with them.

Referenced standards and regulations

- AIR TORQUE actuators are designed, produced and classified according to the European Atex directive 2014/34/EU and U.K. Regulation S.I. 2016 No. 1107 (as amended). Before using the actuators in potentially explosive atmosphere areas, verify the actuator compliance with the required ATEX and UKCA classification.
- ➔ Refer to the nameplate and the ATEX / UKCA safety instructions.
- AT-HDC Series actuators are SIL certified.
- ➔ Refer to the SIL Certificate available from AIR TORQUE for the AT-HDC Series actuators SIL capability.
- Referring to Machine Directive 2006/42/EC and U.K. Regulation S.I. 2008 No. 1597 (as amended), actuators are

classified as “partly machinery” (see Declaration of incorporation). Therefore, the actuators cannot be put into service until the machinery and/or the final system, where the actuators are incorporated, will be declared in compliance with the requirements of the Directive.

- The AIR TORQUE pneumatic actuators are designed according to the criteria of
 - Article 1, paragraph 2. j) ii) of the Pressure equipment directive (PED) 2014/68/EU.
 - Part 1, section 4, schedule 1, paragraph 1. j) ii) of U.K. Regulation S.I. 2016 No. 1105 (as amended).
 Therefore, according to the directive 2014/68/EU and U.K. Regulation S.I. 2016 No. 1105 (as amended) they are not to be considered pressure equipments.
- ➔ Refer to the EU Declaration of Conformity available from AIR TORQUE.

Referenced documentation

The further documents apply in addition to these mounting and operating instructions:

- Mounting and operating instructions for the valve, available from the valve manufacturer,
- Mounting and operating instructions for control and signal devices (positioner, solenoid valve, etc.) available from devices manufacturer,
- ATEX safety manual,
- SIL safety manual for use in safety-instrumented systems.

1.1 Notes on possible severe personal injury

⚠ DANGER

Risk of bursting due to incorrect opening of pressurized equipment or components.

Pneumatic actuators are pressure equipment that may burst when handled incorrectly. Flying projectile fragments or components can cause serious injury or even death.

- ➔ Before starting any work on the actuator disconnect all pneumatic/hydraulic/electrical supplies and discharge the pressure from the actuator.

Risk of severe personal injury due to suspended loads falling.

- ➔ Stay far from suspended or moving loads.
- ➔ Close off and secure the transport paths.

1.2 Notes on possible personal injury

⚠ WARNING

Risk of lifting equipment tipping over and risk of damage to lifting accessories due to exceeding the rated lifting capacity.

- ➔ Use only approved lifting equipment and accessories whose maximum lifting capacity is higher than the actuator weight (including the packaging, if applicable).

Crush hazard arising from moving parts.

The actuator and the valve assembly contains moving parts, which can injure hands or fingers.

- ➔ Do not touch or insert hands or finger into moving parts.
- ➔ Before starting any work on the actuator disconnect all pneumatic/hydraulic/electrical supplies and discharge the pressure from the actuator.
- ➔ Do not touch or insert hands or finger into the yoke while the power supply is connected to the actuator.

Risk of personal injury during actuator air exhaust.

In case of pneumatic power cylinder configuration the actuator is operated with air. As a result, air is exhausted during operation.

- ➔ Install the air exhaust components in such a way that exhaust ports are not located at eye level and the actuator does not discharge at eye level in the working position.
- ➔ Use suitable silencers and vent plugs.
- ➔ Wear eye and hearing protection when working near the actuator.

Risk of personal injury due to compressed springs.

Power modules are under tension due to compressed springs. Consequently, the disassembly could result in serious injury.

- ➔ Before starting any work on the actuator disconnect all pneumatic/hydraulic/electrical supplies and discharge the pressure from the actuator.
- ➔ The actuator must be in the fail position while removing the Power module from the Central module.
- ➔ If Power module service is necessary, contact AIR TORQUE.

Risk of personal injury through incorrect operation, use or installation as a result of information on the actuator being illegible.

Over time, markings, labels and nameplates on the actuator may become covered with dirt or become illegible in some other way. As a result, hazards may go unnoticed and the necessary instructions not followed. There is a risk of personal injury.

- ➔ Keep all relevant markings and inscriptions on the device in a constantly legible status.
- ➔ Immediately renew damaged, missing or incorrect nameplates or labels.

1.3 Notes on possible property damage

NOTICE

Risk of actuator damage due to incorrectly attached slings.

→ Do not attach load-bearing slings to the handwheel or to the travel stop.

Risk of actuator damage due to the use of inappropriate tools.

Certain tools are required to work on the actuator.

→ Do not use damaged tools. Refer to section 15.1 'Tools'.

Risk of actuator damage due to excessively high or low tightening torques.

Observe the specified torques on tightening actuator components (bolts and nuts). Tightening torques above the limits lead to parts wearing out quicker. Parts that are not tightened enough may loosen.

→ Refer to section 15.2 'Tightening torques and sequences'.

Risk of actuator damage due to the use of unsuitable lubricants.

The lubricants to be used depend on the actuator material and operating temperatures. Unsuitable lubricants may corrode and damage the components.

→ Use only lubricants approved by AIR TORQUE. Refer to section 15.3 'Lubricants'.

1.4 Warnings on the device

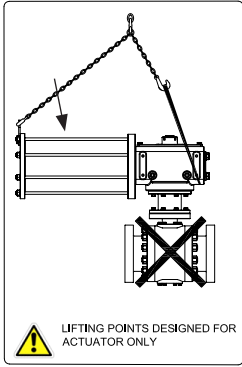
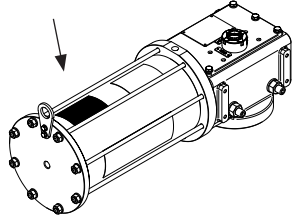
Warning	Meaning of the warning	Location on the device
 <p>LIFTING POINTS DESIGNED FOR ACTUATOR ONLY</p>	<p>Warning against the incorrect use of the lifting brackets on AIRTORQUE actuators. Only attach load-bearing slings to them to vertically lift the actuator on its own (without the valve). The lifting brackets must not be used to vertically lift simultaneously the valve and the actuator.</p>	

2 Markings on the device

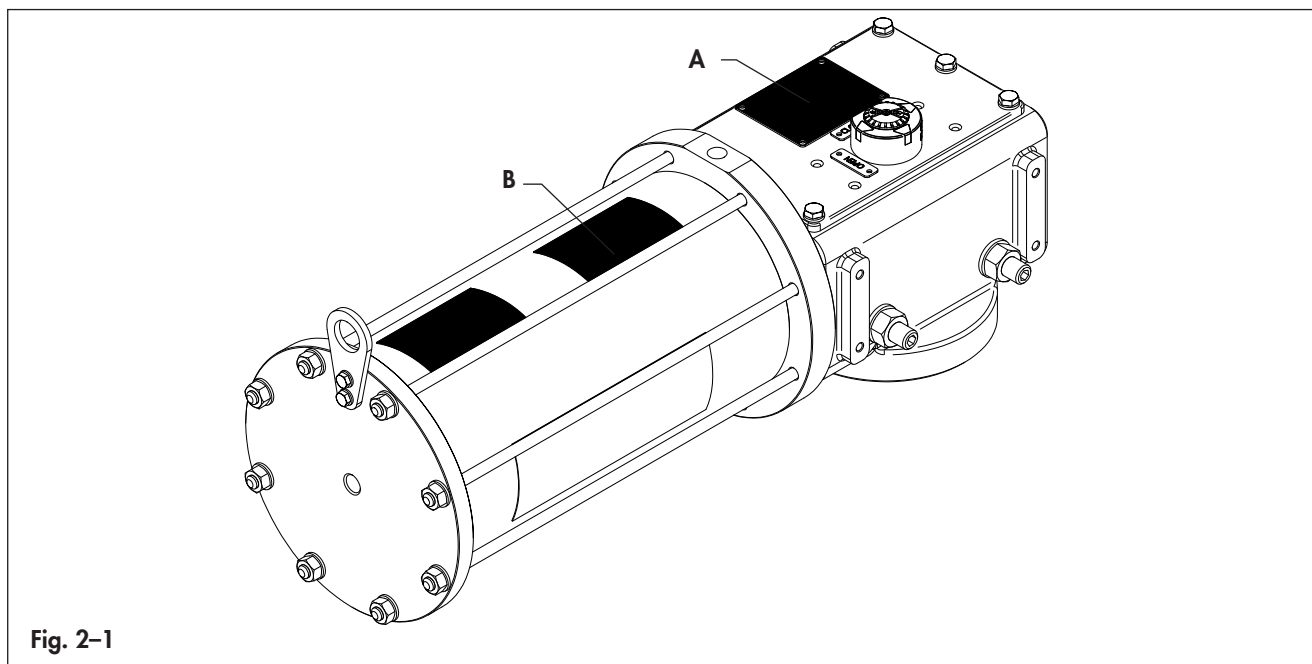

Fig. 2-1

2.1 Actuator nameplate

Refer to Fig. 2-1 for the location of the standard nameplate or with PED on the actuator.

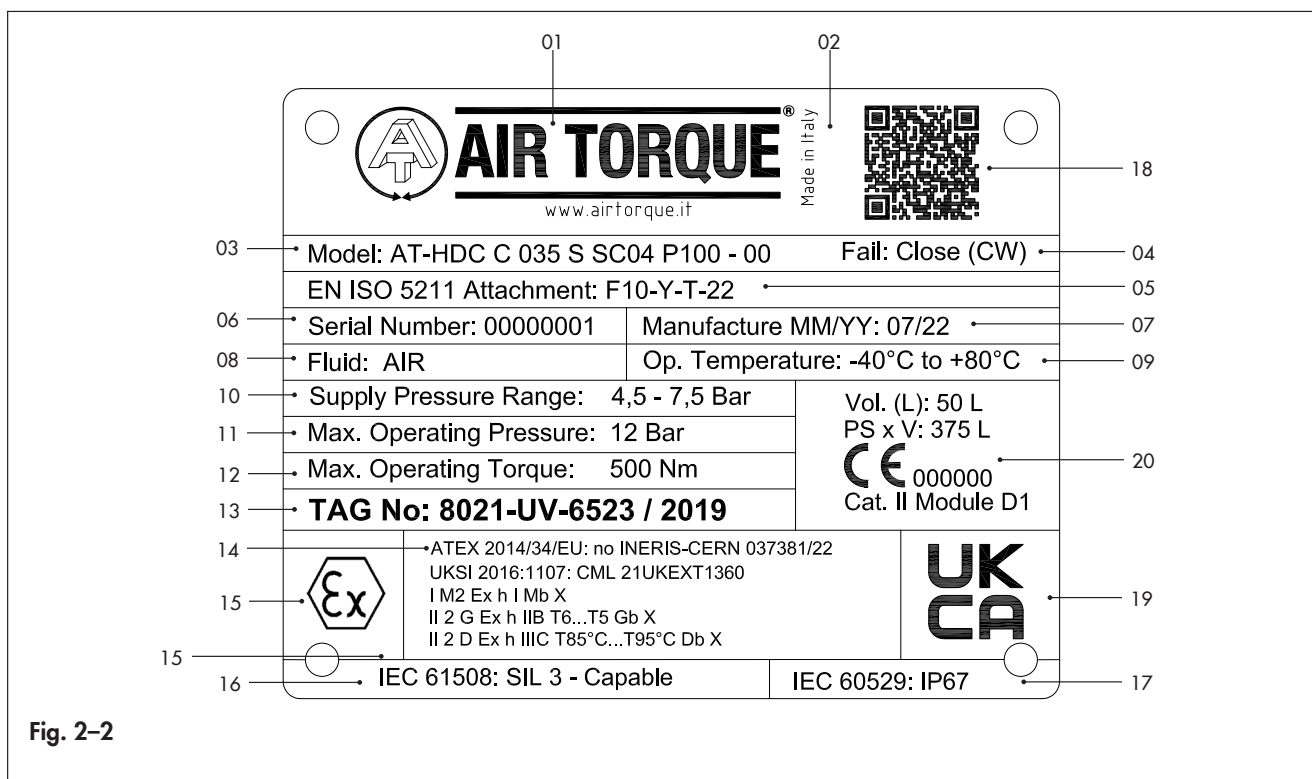

Fig. 2-2

Table 2-1

Position	Description
01	Manufacturer name and trade mark
02	Country of origin
03	Actuator model
04	Fail action
05	Actuator interface
06	Actuator serial number
07	Actuator production date: month/year
08	Fluid (Supply medium)
09	Operating temperature
10	Supply pressure range (if available - marked on request) [bar/psi/kPa]
11	Maximum operating pressure (MOP) [bar/psi/kPa]
12	Actuator maximum output torque at MOT [Nm/Lb•in]
13	Tag number (customer tag number if required)
14	ATEX marking - 2014/34/EU directive
15	EX or CE+EX logo
16	SIL marking - IEC 61508
17	IP marking - IEC 60529
18	QR code
19	UKCA marking - UKSI 2016:1107
20	PED marking - 2014/68/EU directive (Only if applicable).

i Note

Refer to the Catalogue HDC-E for actuators available options and ordering codes.

2.2 Functioning label sample

The functioning label is placed in Fig. 2-1 (Position B) over the Power module.

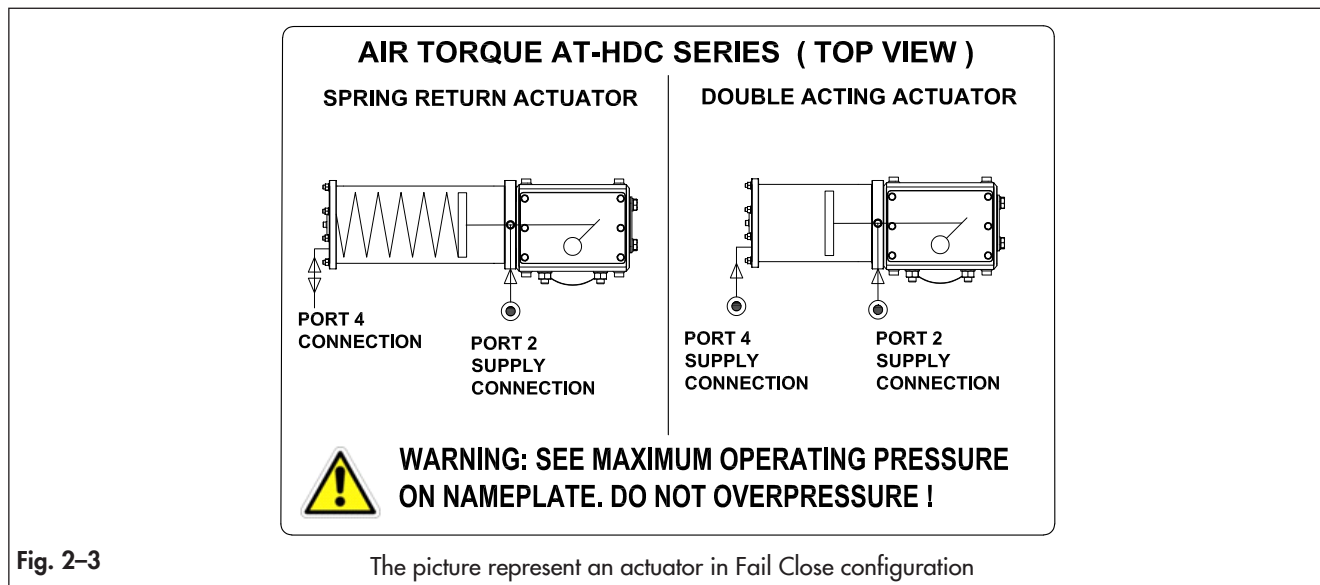

i Note

Refer to section 1.4 for warning labels content and position over the actuator.

3 Design and principle of operation

The AT-HDC actuators are devices for remote operation (on/off or modulating duties) of different industrial valves such as ball valves, butterfly valves and plug valves.

The actuators are available in two configurations: double acting and single acting.

1. DOUBLE ACTING

In case of double acting, air pressure is necessary to stroke the actuator in both opening and closing directions (Fig. 3-1).

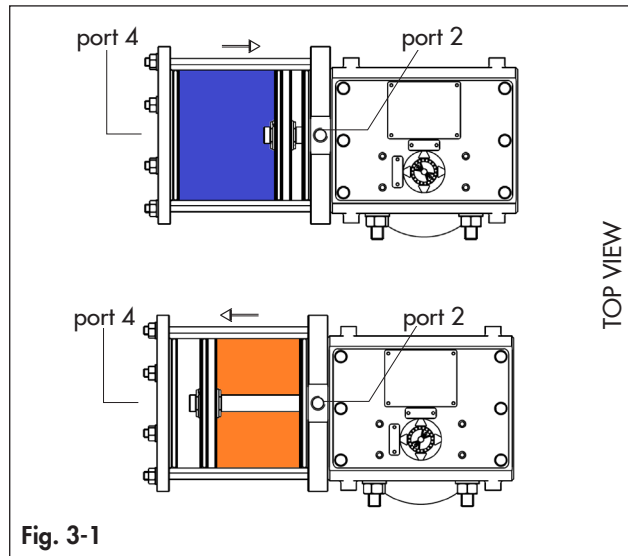

2. SINGLE ACTING

Refer to principle of operation (Fig. 3-2).

Air supplied through Port 2 (A) applies a linear force on the piston surface generating the yoke rotation and driving the valve to a defined position. At the same time the actuator spring is compressed exhausting the air through Port 4.

When air pressure is discharged through Port 2 (B), the spring is automatically released, driving the yoke and the piston back to the original position and thus the valve to the fail-safe position.

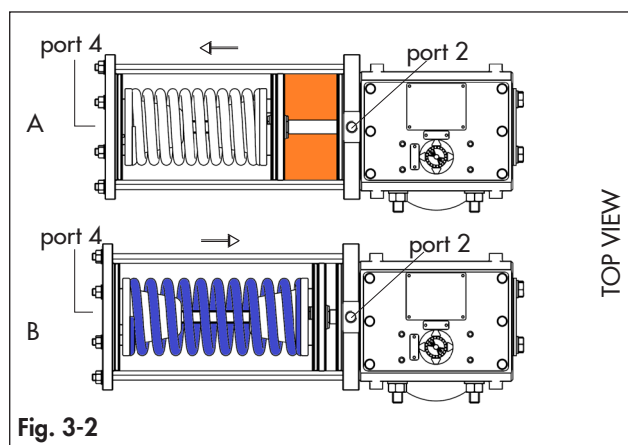

The AT-HDC actuators can be controlled by directly mounted devices or remote control systems.

➔ Refer to section 5.2 'Control and signal devices assembly'.

3.1 Direction of action and fail positions

The standard rotating direction for the AT-HDC actuators is clockwise to close from TOP VIEW.

Standard AT-HDC actuators are designed for 90° rotating angle, with travel stop allowing adjustment (Fig. 3-3) for ±5° on both the close (0°) and open (90°) position.

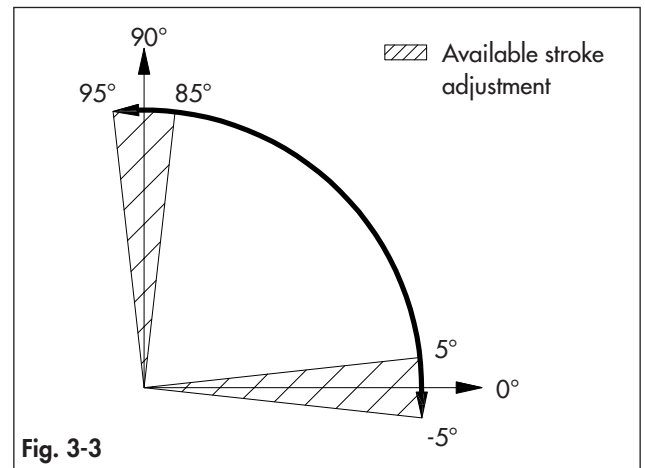

For single acting actuator in case of pressure, power or signal failure the spring drive the actuator in the fail position that can be FAIL OPEN, FAIL CLOSE or in an INTERMEDIATE POSITION according to the control system.

i Note

If the actuator is controlled by a control system the FAIL position may be different from FAIL CLOSE or FAIL OPEN.

➔ Refer to the actuator model technical data for the FAIL position.

➔ Refer to section 2.1 'Actuator nameplate' for the fail action and direction of rotation available options.

3.2 Complementary parts

Manual override systems

Manual override systems are designed to provide manual operation to drive the actuator and the valve in the safe position, in case of any emergency situation, when the supply pressure is not available.

! NOTICE

Risk of actuator damage due to incorrect stroke adjustment.

– Make sure that the actuator and the manual override are correctly oriented, with reference to the rotation direction required.

– Make sure that the stroke of the manual override does not exceed the stroke allowed by the actuator.

Design and principle of operation

- In case of a jackscrew the actuator and the valve are operated rotating a handwheel. (Fig. 3-4)

→ Refer to the EB AT-HDC-JS instructions.

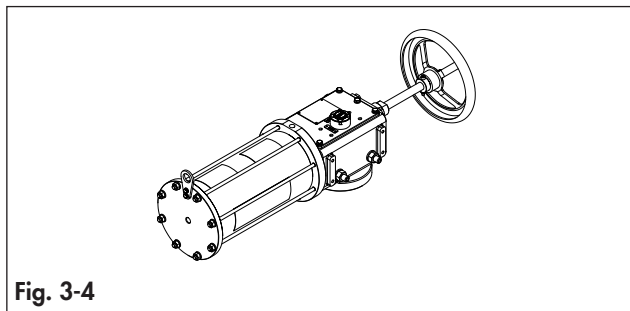

Fig. 3-4

- In case of a hydraulic override the actuator and the valve are operated by means of a hand pump.

→ Refer to the EB AT-HDC-HP instructions.

- In case of a declutchable jackscrew the actuator and the valve are operated rotating a handwheel. (Fig. 3-4)

→ Refer to the EB AT-HDC-JD instructions.

3.3 Technical data

The nameplate provides information on the actuator configuration.

→ Refer to section 2.1 'Actuator nameplate sample'.

→ More informations are available in the actuator model technical data sheet available from AIR TORQUE.

Power operating media

- Use dry or lubricated air, inert gas or sweet dry natural gas.

⚠ WARNING

Risk of bursting due to flammable or dangerous fluid exhausting.

If the actuator is operated with flammable or dangerous fluids this can lead to bursting or poisoning if exhausted carelessly.

→ Convey exhausted fluids in a safe area by means of proper equipment.

i Note

Contact AIR TORQUE for natural gas and any other power operating media's compatibility with AT-HDC actuators.

- Make sure the operating media is compatible with the actuator internal parts and lubricant.
- In case of pressure medium different than Group 2 fluids according to the PED 2014/68/EU, contact AIR TORQUE.
- The operating media must have a dew point equal to -20°C (-4°F) or at least 10°C (18°F) below the ambient temperature.

- The maximum particle size contained into the operating media must not exceed $40\ \mu\text{m}$.

Supply pressure

- The maximum operating pressure is indicated on the actuator nameplate (section 2.1).

- For double acting and single acting actuators the working pressure is from 2.5 bar (36 Psi) up to 12 bar (174 Psi).

→ Refer to the actuator model technical data for output torque values related to the working pressure range.

Operating temperature

The nameplate provides indication on the operating temperatures.

- "S" actuators for standard temperatures from -40°C (-40°F) to $+80^{\circ}\text{C}$ ($+176^{\circ}\text{F}$).

- "H" actuators for high temperatures from -15°C ($+5^{\circ}\text{F}$) to $+150^{\circ}\text{C}$ ($+302^{\circ}\text{F}$).

- "L" actuators for extremely low temperatures from -60°C (-76°F) to $+80^{\circ}\text{C}$ ($+176^{\circ}\text{F}$).

→ Refer to the data sheet HDC50100E for the soft spare parts material.

→ Refer to section 15.3 for the lubricant type in relation to the different working temperature ranges.

Stroking time

The stroking time depends on several factors such as supply pressure, supply system capacity (tubing diameter, pneumatic accessories flow capacity), valve type, valve torque, applied safety factor, cycle frequency, temperatures, etc. Nevertheless, an indication of the stroking time in clearly defined conditions is available in the actuator model technical data sheet.

4 Shipment and on-site transport

The work described in this section is only to be performed by fully trained and qualified personnel.

4.1 Accepting the delivered goods

After receiving the shipment, proceed as follows:

3. Check the scope of delivery. Check that the specifications on the actuator nameplate match the specifications in the delivery note. Refer to section 2 for nameplate details.
4. Check the shipment for transportation damage. Report any damage to AIR TORQUE and the forwarding agent (refer to delivery note).

Determine the weight and dimensions of the units to be lifted and transported in order to select the appropriate lifting equipment and lifting accessories. Refer to the transport documents and the section 3.3 'Technical data'.

4.2 Removing the packaging from the actuator

Observe the following sequence:

- Do not open or remove the packaging until immediately before mounting the actuator.
- Leave the actuator in its transport container or on the pallet to transport it on site.
- Dispose and recycle the packaging in accordance with the local regulations.

4.3 Transporting and lifting the actuator

⚠ DANGER

Risk due to suspended loads falling.

- Stay far from suspended or moving loads.
- Close off and secure the transport paths.

⚠ WARNING

Risk due to suspended components falling.

Due to the heavy weight of the components and different mounting configurations available of the valve and actuator in the pipeline, suspended components may fall and cause serious injury.

- If necessary, use proper extra supporting components.
- Contact AIR TORQUE in case of additional lifting points needed due to non standard lifting direction.

⚠ WARNING

Risk of lifting equipment tipping over and risk of damage to lifting accessories due to exceeding the rated lifting capacity.

- Use only approved lifting equipment and accessories whose maximum lifting capacity is higher than the actuator weight (including the packaging, if applicable).

ⓘ NOTICE

Risk of actuator damage due to incorrectly attached slings.

Only attach load slings to vertically lift the actuator on its own. The lifting points must not be used to lift the entire actuator and valve assembly.

- Do not attach load-bearing slings to the complementary or accessory components.
- Do not use damaged or defective slings.
- Do not shorten the slings with knots or bolts or other makeshift devices.
- Observe lifting instructions (see section 4.3.2).

💡 Tip

Our aftersales service (aftersales@airtorque.it) can provide more detailed transport and lifting instructions on request.

4.3.1 Transporting the actuator

The actuator can be transported using proper lifting equipment (e.g. crane or forklift).

- Leave the actuator in its transport container or on the pallet to transport it.
- Observe the transport instructions.

Transport instructions

- Protect the actuator against external influences (e.g. impact).
- Do not damage the corrosion protection (paint, surface coatings). Repair any damage immediately.
- Protect the actuator against moisture and dirt.
- Observe permissible storing temperatures (refer to the section 3.3 'Technical data').

4.3.2 Lifting the actuator

Observe the ruling regulations concerning the lifting operations.

To mount the actuators onto the valve, use lifting equipment (e.g. crane or forklift) to lift it.

Do not drill extra holes into the actuator.

ⓘ Note

In case of additional lifting points needed due to non standard lifting direction, contact AIR TORQUE.

Do not use the actuator lifting points to lift the entire actuator and valve assembly.

- Refer to the warning labels over the actuator (section 1.4)
- Use appropriate tackles and slings to lift the actuator.
- Refer to technical data sheet of the actuator for the weight.

Lifting instructions

- Secure slings on the object to be transported against slipping.

Shipment and on-site transport

- Make sure the slings can be removed from the actuator once it has been mounted on the valve.
- Prevent the actuator from tilting or tipping.
- Do not leave loads suspended when interrupting work for longer periods of time.
- Use a hook with safety latch to secure the slings from slipping during lifting and transporting.

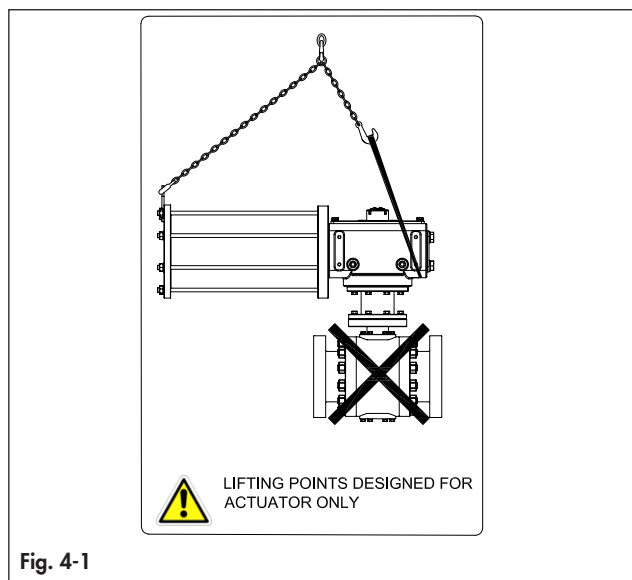

- Do not damage the corrosion protection (paint, surface coatings). Repair any damage immediately.
- Protect the actuator against moisture and dirt.
- Make sure that the ambient air is free of acids or other corrosive media.
- Do not place any objects on the actuator.
- Keep for future references the relevant technical documentation of the actuator.
- Do not remove the plastic plugs from the air connections.

Tip

Our after-sales service (aftersales@airtorque.it) can provide more detailed storage instructions on request.

4.4 Storing the actuator

NOTICE

Risk of actuator damage due to improper storage.

- ➔ Observe the storage instructions.
- ➔ Observe the rubber components storage instructions (T 3.3.3.1 EN).
- ➔ Avoid long storage times. Contact AIR TORQUE in case of different storage conditions or long storage periods.

Note

We recommend regularly checking the actuator and the prevailing storage conditions during long storage times.

Storage instructions

- Store the actuator in a clean and dry place.
- Temperature limits are defined by the rubber components material.
- ➔ Refer to the 'Rubber components storage instruction' (T 3.3.3.1 EN).
- When the valve and actuator are already assembled, also observe the valve storage conditions. Refer to the valve documentation.
- Protect the actuator against external influences (e.g. impact).
- Secure the actuator in the stored position against slipping or tipping over.

5 Mounting and assembly

The work described in this section is only to be performed by fully trained and qualified personnel.

5.1 Preparation for installation

If the actuator was shipped already assembled over the valve, the setting of the actuator and control system (if available) should have been already done by the valve manufacturer or automation center.

If the actuator was shipped separately from the valve, the setting of the actuator and control system must be done while assembling the actuator on top of the valve.

5.2 Control and signal devices assembly

The AT-HDC actuators can be controlled by directly mounted devices or remote control systems. Therefore AIR TORQUE actuators are designed with:

- Ancillary attachment to mount control and signal devices by means of a bracket.
 - Threaded supply/exhaust connections according to EN 15714-3 and VDI/VDE 3845-1 which permit the standardized attachment of remote control systems.
- ➔ Refer to the documentation available from control and signal devices manufacturers for mounting and operating instructions.

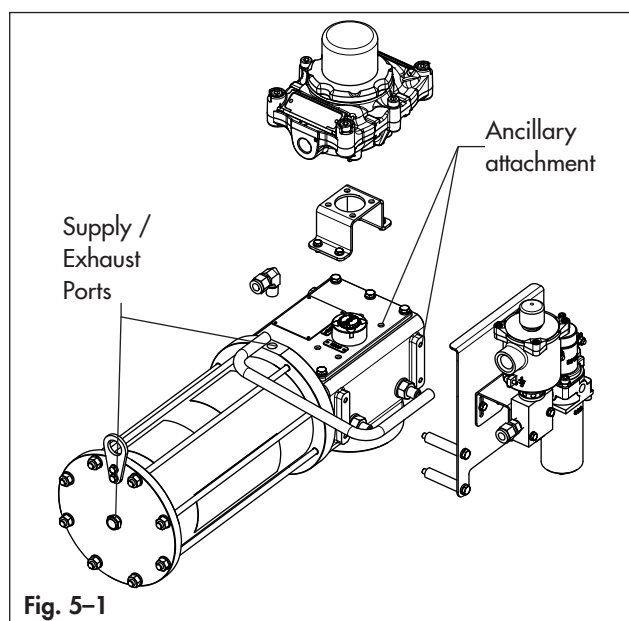

Fig. 5-1

5.3 Mounting the actuator over the valve

⚠ DANGER

Risk of bursting in the actuator

Pneumatic actuators are pressure equipment that may burst when handled incorrectly. Flying projectile fragments or components can cause serious injury or even death.

- ➔ Before starting any work on the actuator disconnect all pneumatic / hydraulic / electrical supplies and discharge the pressure from the actuator.

⚠ WARNING

Crush hazard arising from moving parts.

The actuator and the valve assembly contains moving parts, which can injure hands or fingers.

- ➔ Do not touch or insert hands or finger into moving parts.
- ➔ Before starting any work on the actuator disconnect all pneumatic / hydraulic / electrical supplies and discharge the pressure from the actuator.
- ➔ Do not impede the movement of the yoke by inserting objects into the actuator.

⚠ WARNING

Risk of damage and malfunction due to torque limit violation.

Considering the maximum actuator output torque, the maximum air supply pressure and the maximum valve torque, according to ISO 5211, the actuator maximum transmissible output torque must not exceed the torque limit in relation to the available ISO flange and the drive shaft connection.

- ➔ Refer to section 2 'Markings on the device' for nameplate details.

ⓘ NOTICE

Risk of actuator damage due to excessively high or low tightening torques.

Observe the specified torques on tightening actuator components (bolts and nuts). Tightening torques above the limits lead to parts wearing out quicker. Parts that are not tightened enough may loosen.

- ➔ Refer to section 1.5.2 'Tightening torques'.

Before mounting the actuator over the valve, make sure the following conditions are met:

- The actuator is not damaged.
- The type designation, material and temperature range of the actuator match the ambient conditions (temperatures etc.). Refer to 'Markings on the device' in section 2 for nameplate details.
- Check compatibility of the valve stem to the actuator bore. The length, dimension and configurations must match.
- Check compatibility of actuator, valve and bracket bolting pattern. (Fig. 5-2).
- Before fitting the actuator over the valve, make sure that the actuator and the valve are correctly oriented, with reference to the rotation direction and fail action required.
- Make sure that the tubing, fittings and seals connected to the actuator are cleaned to prevent foreign matter/objects entering into the actuator's chambers.

Mounting and assembly

- When fitting accessories over the actuators, assemble them in such a way that the emergency controls are easily accessible for emergency manual operation.
- Check that the exhaust ports are not obstructed.
- Remove the plugs from the actuator air connections during installation and operation, protect and close the air connections which may not be used immediately.
- Make sure that the operating pressure media composition used for the actuator operation meets the operating conditions given in this manual and corresponds to what the ac-

tuator was manufactured for. Refer to section 3 'Design and principles'.

- It is the user responsibility to ensure that actuator and control components must be protected from electrical spikes, surge and lightning strikes as well as all magnetic fields.
- Prevent any dangerous and/or corrosive substances in the working environment enter into the internal chambers by using adequate filters and/or solenoid valves and/or any other appropriate system.

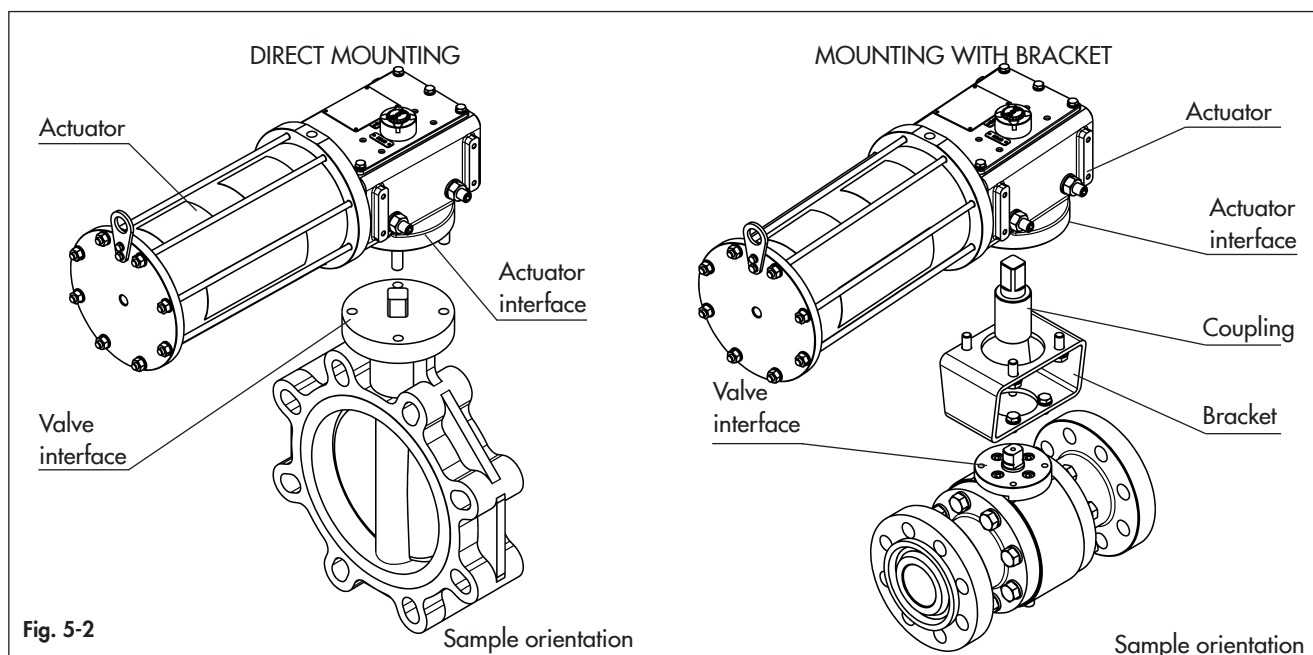

Fig. 5-2

Sample orientation

Sample orientation

The mounting of the actuator can be performed by:

- Mounting directly the actuator over the valve interface
- Assembling a bracket and a coupling between the actuator and the valve.

Refer to Fig. 5-2 and proceed as follows to mount the actuator over the valve:

- Disconnect any electrical/pneumatic/hydraulic power supply.
- Lay out the necessary material and tools to have them ready during mounting.
- The actuator is supplied in the fail position (for single-acting), so drive the valve in the right position as per the actuator fail position.
- Clean the actuator's bore and the bottom flange.
- Clean the valve and the actuator interface to remove completely any lubricant.
- Place the bracket, if any, over the valve flange, tighten all bolts and nuts partially applying the tightening torque.

⚠ WARNING

Risk of damage due to incorrect alignment

- ➔ Support the actuator with the lifting equipment until the connection bolts are completely tightened.
- ➔ Make sure to align correctly the dowel pins or the spigot, if any.

- Assemble the coupling at first into the valve stem before the assembly of the actuator.
- Lift the actuator.
- Align the valve stem/coupling to the actuator's bore.
- Carefully lower the actuator and engage the valve stem/coupling into the actuator's bore without forcing and driving the actuator into the position only with the weight of the actuator itself.
- Fix the actuator over the valve flange/bracket with the connection bolts and nuts.
- Tighten the connection bolts and nuts on both sides at the correct tightening torque.
- ➔ Refer to ISO 5211 for correct tightening torques.

⚠ WARNING***Risk due to suspended components falling.***

Due to the heavy weight of the components and different mounting configurations available of the valve and actuator in the pipeline, suspended components may fall and cause serious injury.

- *If necessary, use proper extra supporting components.*
 - *Contact AIR TORQUE in case of additional lifting points needed due to non standard lifting direction.*
-

6 Start-up

The work described in this section is only to be performed by fully trained and qualified personnel.

⚠ WARNING***Risk of bursting in the actuator***

Pneumatic actuators are pressure equipment that may burst when handled incorrectly. Flying projectile fragments or components can cause serious injury or even death.

- ➔ *Before starting any work on the actuator disconnect all pneumatic / hydraulic / electrical supplies and discharge the pressure from the actuator.*
-

⚠ WARNING***Crush hazard arising from moving parts.***

The actuator and the valve assembly contains moving parts, which can injure hands or fingers.

- ➔ *Do not touch or insert hands or finger into moving parts.*
 - ➔ *Before starting any work on the actuator disconnect all pneumatic / hydraulic / electrical supplies and discharge the pressure from the actuator.*
 - ➔ *Do not impede the movement of the yoke by inserting objects into the actuator.*
-

Connect the actuator to the pressure supply line and/or to the control system, if any, with fittings and pipes as per actuator model and plant specifications.

7 Operation

The work described in this section is only to be performed by fully trained and qualified personnel.

⚠ WARNING

Risk of personal injury during actuator air exhaust.

In case of pneumatic power cylinder configuration the actuator is operated with air. As a result, air is exhausted during operation.

- *Install the air exhaust components in such a way that exhaust ports are not located at eye level and the actuator does not discharge at eye level in the work position.*
- *Use suitable silencers and vent plugs.*
- *Wear eye and hearing protection when working near the actuator.*

⚠ WARNING

Crush hazard arising from moving parts.

The actuator and the valve assembly contains moving parts, which can injure hands or fingers.

- *Do not touch or insert hands or finger into moving parts.*
- *Before starting any work on the actuator disconnect all pneumatic/hydraulic/electrical supplies and discharge the pressure from the actuator.*
- *Do not impede the movement of the yoke by inserting objects into the actuator.*

⚠ WARNING

Risk of personal injury through incorrect operation, use or installation as a result of information on the actuator being illegible.

Over time, markings, labels and nameplates on the actuator may become covered with dirt or become illegible in some other way. As a result, hazards may go unnoticed and the necessary instructions not followed. There is a risk of personal injury.

- *Keep all relevant markings and inscriptions on the device in a constantly legible state.*
- *Immediately renew damaged, missing or incorrect nameplates or labels.*

The actuator can be operated after connecting it to the supply line and adjusting the stroke.

Double acting actuators require alternate connection ports to be pressurized and vented for stroking.

Single acting actuators work on air stroke or spring stroke by pressurizing or venting respectively the connection port.

- Refer to section 3 'Design and principle of operation'.
- Choose the accessories, control elements, tubing and fittings for adequate flow rates so as not to constrict flow or cause high pressure drop affecting the performance of the actuator.
- In case the plant specifications require a supply pressure for the actuator lower than the maximum supply pressure

marked in the actuator nameplate, label the actuator with reduced supply pressure (e.g. "Max. supply pressure limited to ... bar").

8 Malfunctions

The work described in this section is only to be performed by fully trained and qualified personnel.

8.1 Troubleshooting

Malfunction	Possible reasons	Reccomended action
Uneven rotation	Inadeguate supply	Check the supply system and make sure that the supply pressure is correct.
	Lubricant missing	Disassemble the actuator, lubricate all the sliding parts and reassemble the actuator.
	Worn components	Disassemble the actuator, inspect and replace the worn/damaged components.
	Faulty valve	Check the valve documentation and contact the manufacturer.
	Control system	Make sure the control system components are correctly assembled. Check the control system documentation and contact the manufacturer.
	Wrong sizing	Check valve and actuator torques
Incomplete rotation	Incorrect stroke adjustment	Observe indications in section 9.5.9 for correct stroke adjustment.
	Foreign object left inside	Disassemble the actuator, inspect and remove any foreign object.
	Incorrect assembly after maintenance	Disassemble and reassemble the actuator correctly.
	Control system	Make sure the control system components are correctly assembled. Check the control system documentation and contact the manufacturer.
	Faulty valve	Check the valve documentation and contact the manufacturer.
	Wrong sizing	Check valve and actuator torques
Loss of power	Inadeguate supply pressure	Check the control system and make sure that the supply pressure is correct.
	Supply pipe blocked, compressed or with sealing problems	Check all the piping and fittings, remove any foreign object/damaged component.
	Power module seals leakage	Disassemble the power module, inspect and replace any damaged seals.
	Air exhaust hole blocked	Remove caps or foreign objects from the exhaust hole.
	Faulty valve	Check the valve documentation and contact the manufacturer.

i Note

Contact AIR TORQUE (aftersales@airtorque.it) for malfunctions not listed in the table.

8.2 Emergency action

The plant operator is responsible for emergency action to be taken in the plant.

9 Service

The work described in this section is only to be performed by fully trained and qualified personnel.

⚠ DANGER

Risk of bursting due to incorrect opening of pressurized equipment or components.

Pneumatic actuators are pressure equipment that may burst when handled incorrectly. Flying projectile fragments or components can cause serious injury or even death.

- ➔ Before starting any work on the actuator disconnect all pneumatic/hydraulic/electrical supplies and discharge the pressure from the actuator.

⚠ WARNING

Risk of personal injury due to compressed springs.

Power modules are under tension due to compressed springs. Consequently, the disassembly could result in serious injury.

- ➔ Before starting any work on the actuator disconnect all pneumatic/hydraulic/electrical supplies and discharge the pressure from the actuator.
- ➔ The actuator must be in the fail position while removing the Power module from the Central module.
- ➔ If Spring unit service is necessary, contact AIR TORQUE.

⚠ WARNING

Risk of personal injury during actuator air exhaust.

In case of pneumatic power cylinder configuration, the actuator is operated with air. As a result, air is exhausted during operation.

- ➔ Install the air exhaust components in such a way that exhaust ports are not located at eye level and the actuator does not discharge at eye level in the working position.
- ➔ Use suitable silencers and vent plugs.
- ➔ Wear eye and hearing protection when working near the actuator.

⚠ WARNING

Crush hazard arising from moving parts.

The actuator and the valve assembly contains moving parts, which can injure hands or fingers.

- ➔ Do not touch or insert hands or finger into moving parts.
- ➔ Before starting any work on the actuator disconnect all pneumatic/hydraulic/electrical supplies and discharge the pressure from the actuator.

ⓘ NOTICE

Risk of actuator damage due to excessively high or low tightening torques.

Observe the specified torques on tightening actuator components (bolts and nuts). Tightening torques above the limits lead to parts wearing out quicker. Parts that are not tightened enough may loosen.

- ➔ Observe the specified tightening torques in section 1.5.2.

ⓘ Note

- The product warranty becomes void if service or repair work not described in these instructions is performed without prior agreement by AIR TORQUE's After-sales Service.
- Only use original spare parts by AIR TORQUE, which comply with the original specifications.

With the information given below, AIR TORQUE provides the end user with all the required information necessary for service. Under normal conditions, the actuator requires only periodic observation to ensure proper operation. However, due to critical working conditions and a natural components ageing effect even if properly stored, a preventive service program is essential to ensure good performance, safe operation and an extended life of the actuator, AIR TORQUE recommend to perform the service not later than reaching the first limit between cycles number limit and time limit. One cycle consists of nominal 90° angular travel in both directions (i.e. 90° to open + 90° to close).

- ➔ Spare kits are available for seals and bearing replacement (HDC50100E).
- ➔ Refer to the Rubber products storage instructions (T3.3.3.1 EN).

Table 9-1

ACTUATOR MODEL	CYCLES NUMBER LIMIT	TIME LIMIT
AT-HDC 035	350000	48 Months/ 4 years from installation or
AT-HDC 045	250000	
AT-HDC 055	150000	60 Months/5 years from production date.
AT-HDC 065	75000	

Cycles number limit and time limit have been defined for actuators with sizing safety factor at least 1.3 and operating at specific conditions:

- Supply pressure ≤ 5,5 bar (79,77 Psi).
- Supply media: air or inert gas, not corrosive, dry or lightly lubricated, without impurity.
- Working temperature from 10°C up to 30°C (50°F up to 86°F).

ⓘ Note

Any deviation from these operating conditions may affect the recommended cycles number limit and time limit.

- ➔ For actuators with "H" or "L" operating temperatures (refer to section 3.3 'Technical data') the recommended cycles number and time limit may be reduced by 50%.
- ➔ For actuators operating in Safety instrumented systems where a certain SIL level is required, cycles number limit and time limit may be significantly reduced.

9.1 Preparation for servicing

- Lay out the necessary material and tools to have them ready for the intended work.
- Put the actuator out of operation (see the 'Decommissioning' section).
- Remove the actuator from the valve (see the 'Removal' section).

9.2 Part List

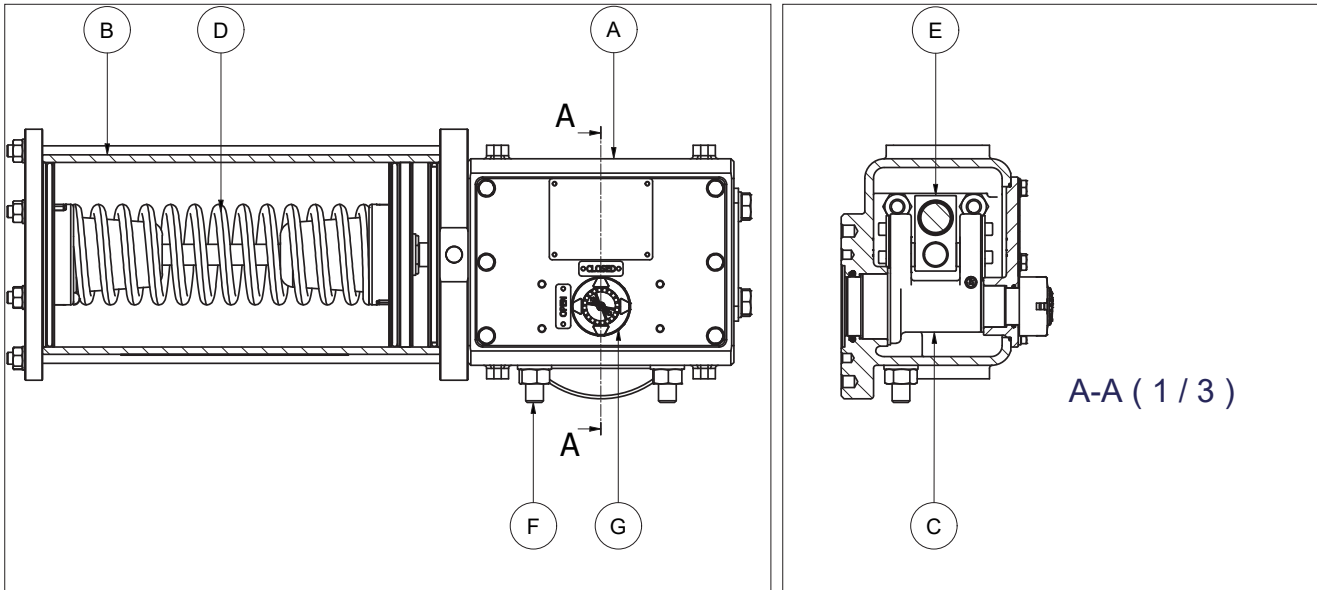

PART NUMBER	DESCRIPTION
A	CENTER MODULE
B	POWER MODULE
C	YOKE MECHANISM
D	SPRING PRELOADED UNIT
E	GUIDING BLOCK
F	ADJUSTABLE STOPPER
G	POSITION INDICATOR

9.3 Disassembly

⚠ WARNING

Risk of personal injury due to compressed springs.

Spring modules are under tension due to compressed springs. Consequently, the disassembly could result in serious injury.

- Before starting any work on the actuator disconnect all pneumatic/hydraulic/electrical supplies and discharge the pressure from the actuator.
- The actuator must be in the fail position while removing the Power module from the Central module.
- If Spring unit service is necessary, contact AIR TORQUE.

ⓘ NOTICE

Risk of components damage due to incorrect storage.

Store the single components in a clean and safe area once disassembled, before proceeding with the service and the reassembly.

9.3.1 Stroke adjustment screws removal

- Loosen the nuts (01ZU).
- Unscrew and remove the screw (01ZW), the washer (01ZV) and the o-ring (01YR). A minimum pressurization to the actuator may be needed in case the screw is blocked in position due to the yoke contact pressure.
- Refer to the functioning labels to correctly pressurize the actuator.

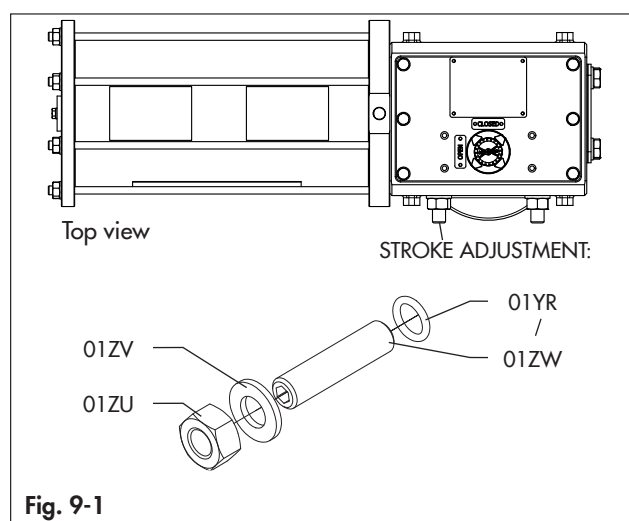

Fig. 9-1

ⓘ Note

The screws (01ZW) may have different lengths depending on the actuator stroking range. Make sure to match the correct adjustment screws to the actuator as disassembled.

9.3.2 (W) Welded central module configuration disassembly

In case of casted configuration please refer to chapter 9.3.3

9.3.2.1 Cover removal

Refer to Fig. 9-2 and Fig. 9-3.

- Remove the position indicator (01ZS) and indicator screw (01YT).
- Remove the spring clip (01ZC) with a proper circlip plier.
- Remove the washer (01ZD) and the upper thrust bearing (01ZE).
- Unscrew all the screws (01ZR) with the washers (01ZQ).
- Remove the cover (01AC) and the gasket (01AD).

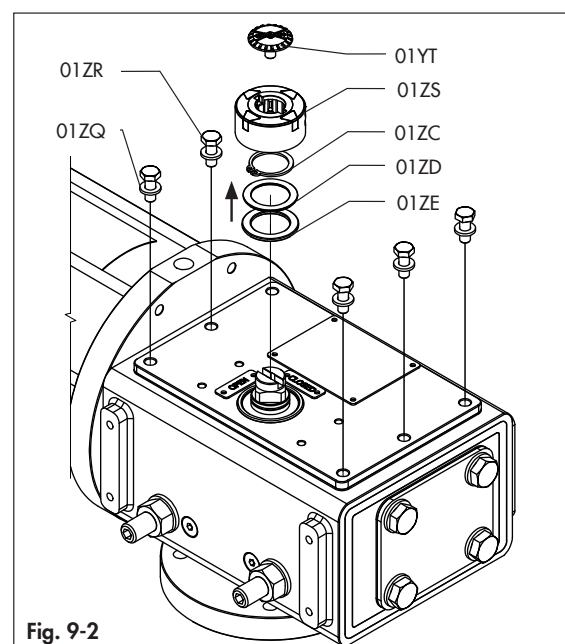

Fig. 9-2

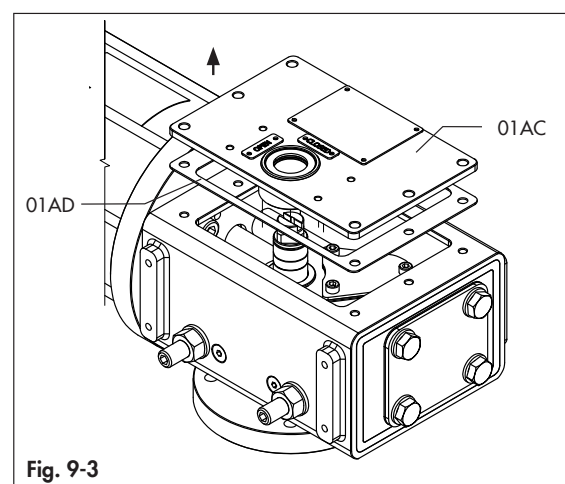

Fig. 9-3

9.3.2.2 Central module disassembly

ⓘ Note

In case of actuator with complementary parts refer to the corresponding instructions:

- Jackscrew → EB AT-HDC-JS,
- Declutchable jackscrew → EB AT-HDC-JD,
- Hydraulic pump → EB AT-HDC-HP,
- Damper → EB AT-HDC-DP.

- Unscrew the screws (01YU) from the yoke cover (01AO). (Fig. 9-4)
- Remove the yoke cover (01AO), the gasket (01AU) and upper thrust bearing (01ZE) (Fig. 9-4).

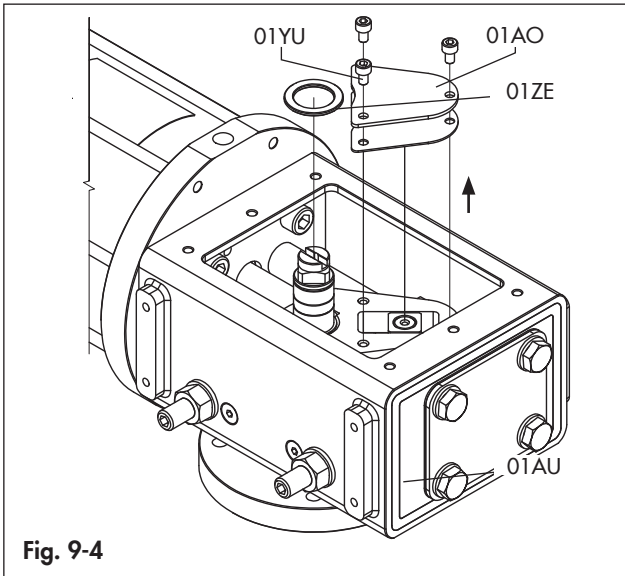

Fig. 9-4

- Remove the yoke pin (01AE) by means of a screw or a proper tool (Fig. 9-5).
- Remove the upper sliding block (01AR) from the yoke, the sliding plates (01AS) and the bottom thrust bearing (01YW) (Fig. 9-5).

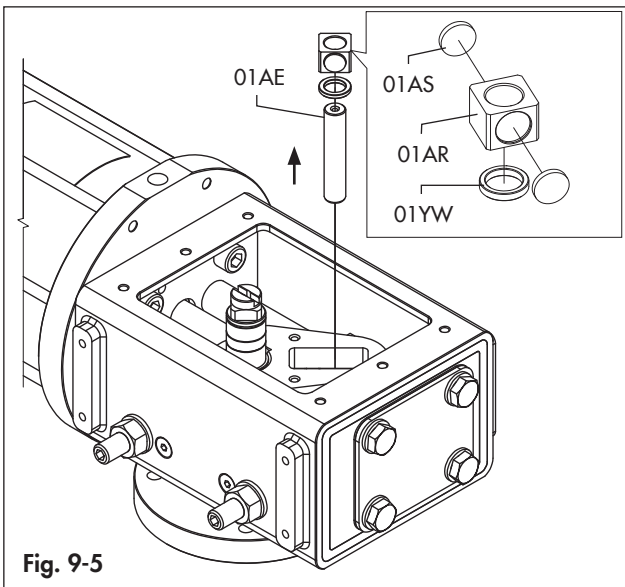

Fig. 9-5

The yoke is now separated by the sliding block and it is possible to rotate it in the power module side direction allowing access to the center body. In case of Double Acting actuator it is possible to slightly pressurize Port 4 in order to move the sliding block and provide the required space to the yoke.

- Remove the drive shaft (01AH), by applying a light force on top of it and the key (01YY) from the bottom (Fig 9-6).

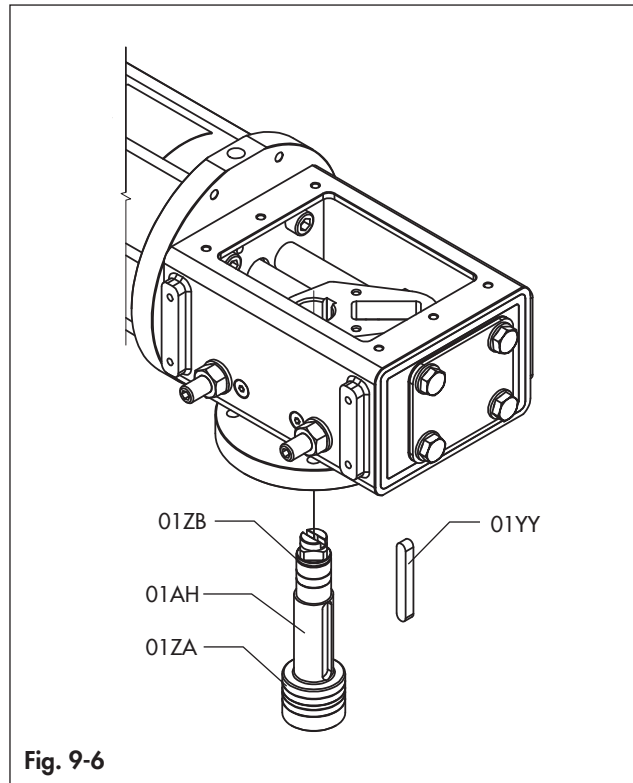

Fig. 9-6

- Remove the screws (03ZZ), the washers (03ZY) and the nuts (03ZX) from the double acting closing module. (Fig. 9-7).
- Remove the plate (03AA) and the gasket (03AB).
- The guide bar (01AQ) is now free and it is possible to remove it by sliding it aside.

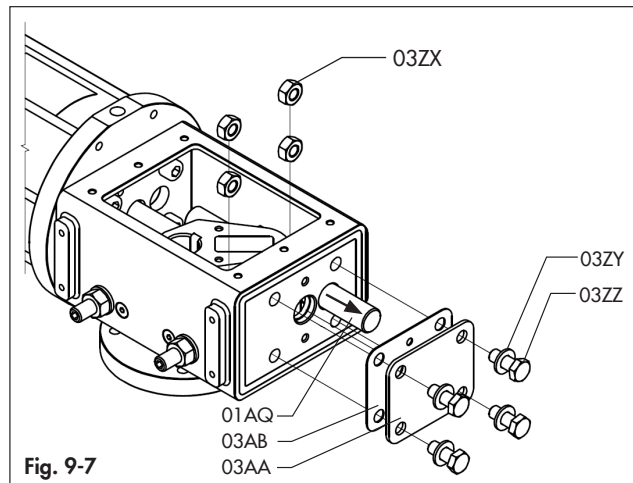

Fig. 9-7

- Remove the yoke (01AN). Carefully remove also the lower sliding block (01AR) from the yoke lower wing, the sliding plates (01AS) and the thrust bearing (01YV). (Fig. 9-8).

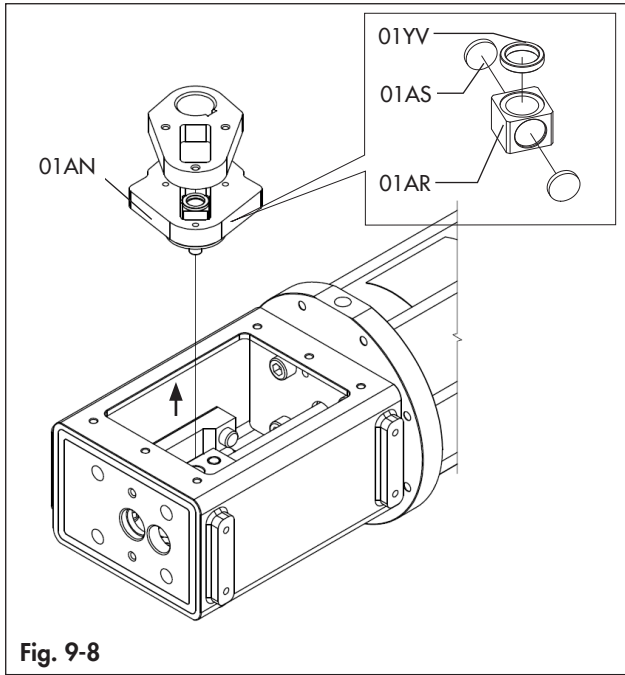

Fig. 9-8

- Unscrew the screws (01YU) and remove the lower yoke cover (01AO) and the gasket (01AU). (Fig. 9-9).

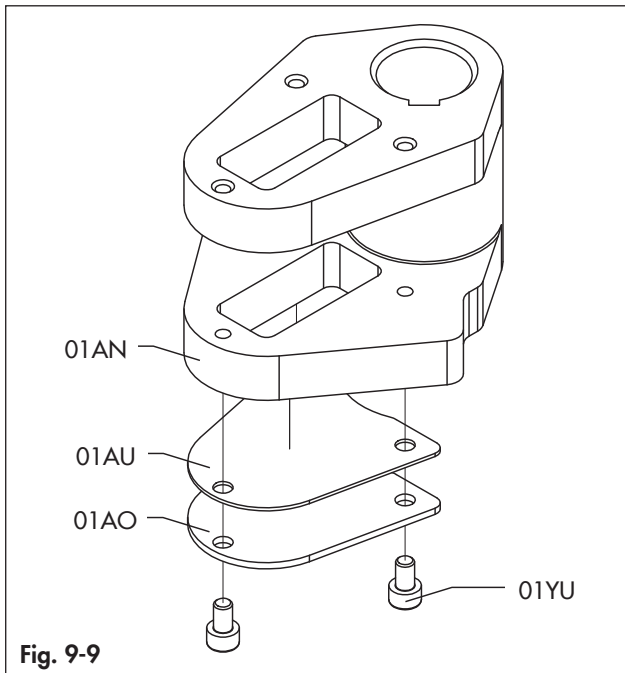

Fig. 9-9

- Unscrew the screw (01YX) inside the sliding block (01AF) (Fig. 9-10).
- Push down the pin (02AI) until it falls inside the housing (Fig. 9-10).

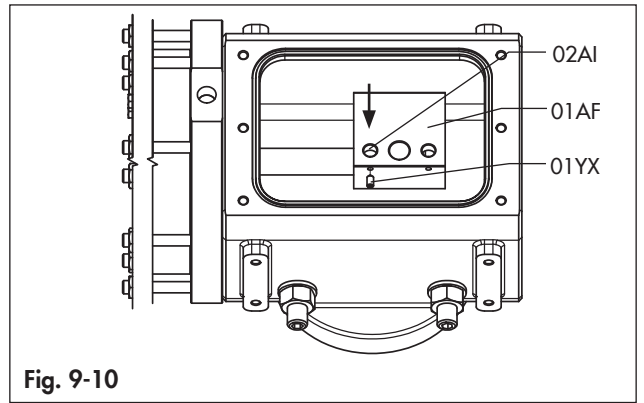

Fig. 9-10

- Remove the screws (02ZZ) (Fig. 9-11).

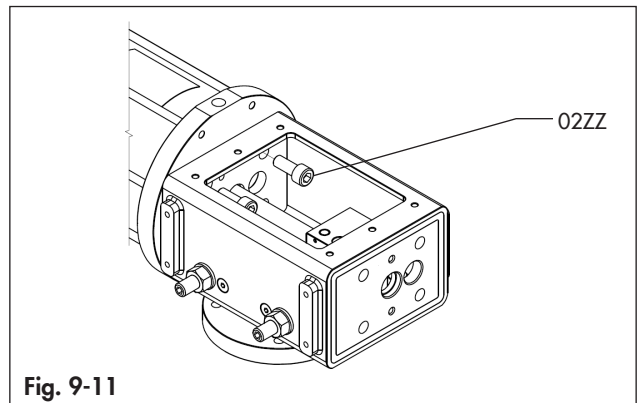

Fig. 9-11

- Remove the power module and the sliding block (01AF) (Fig. 9-12).

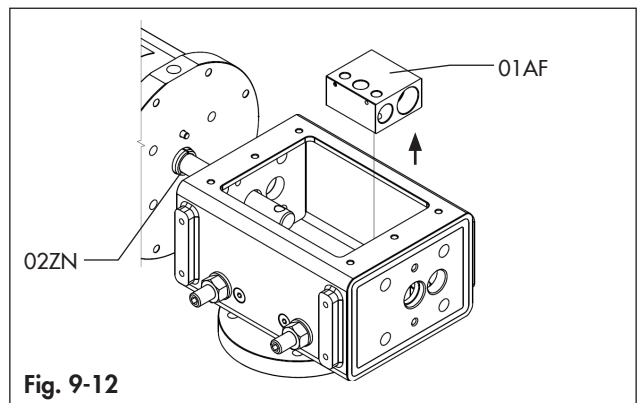

Fig. 9-12

i Note

The component (02ZN), may result loosen since they are not fixed. (Fig. 9-12).

For the power module disassembly instructions please refer to chapter 9.2.4

9.3.3 (C) Casted central module configuration disassembly

9.3.3.1 Cover removal

Refer to Fig. 9-13 and Fig. 9-14.

- Remove the position indicator (01ZS) and indicator screw (01YT).
- Unscrew all the screws (01ZR) with the washers (01ZQ).
- Remove the cover (01AC) and the oring (01AD).

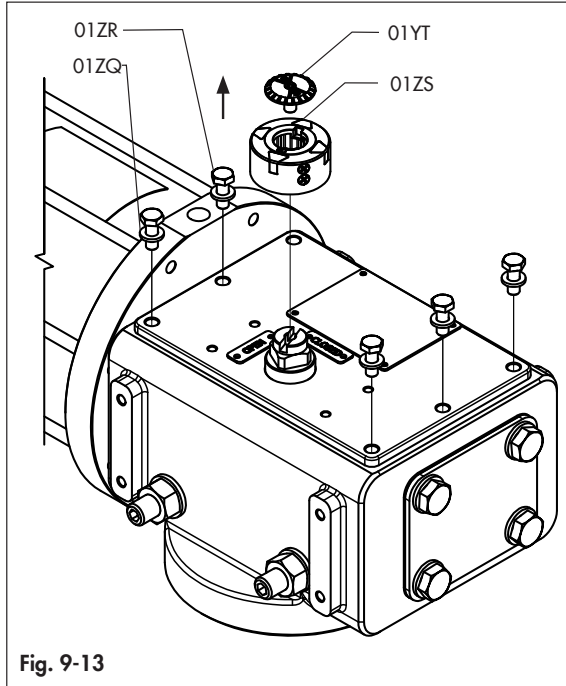

Fig. 9-13

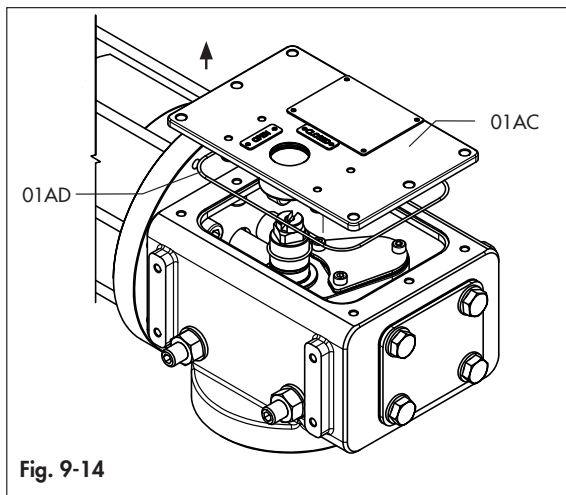

Fig. 9-14

9.3.3.2 Central module disassembly

i Note

In case of actuator with complementary parts refer to the corresponding instructions:

- Jackscrew → EB AT-HDC-JS,

- Declutchable jackscrew → EB AT-HDC-JD,
- Hydraulic pump → EB AT-HDC-HP,
- Damper → EB AT-HDC-DP.

- Unscrew the screws (01YU) from the yoke cover (01AO). (Fig. 9-15)
- Remove the yoke cover (01AO), the gasket (01AU) and upper thrust bearing (01ZE) (Fig. 9-15).

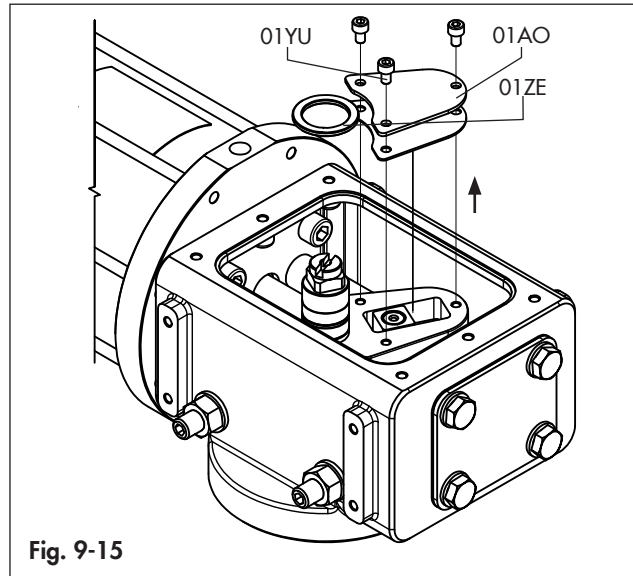

Fig. 9-15

- Remove the yoke pin (01AE) by means of a screw or a proper tool (Fig. 9-16).
- Remove the upper sliding block (01AR) from the yoke, the sliding plates (01AS) and the bottom thrust bearing (01YW) (Fig. 9-16).

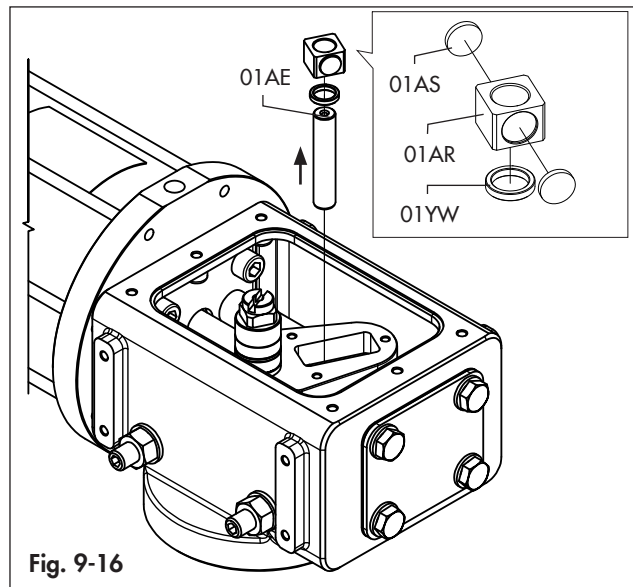
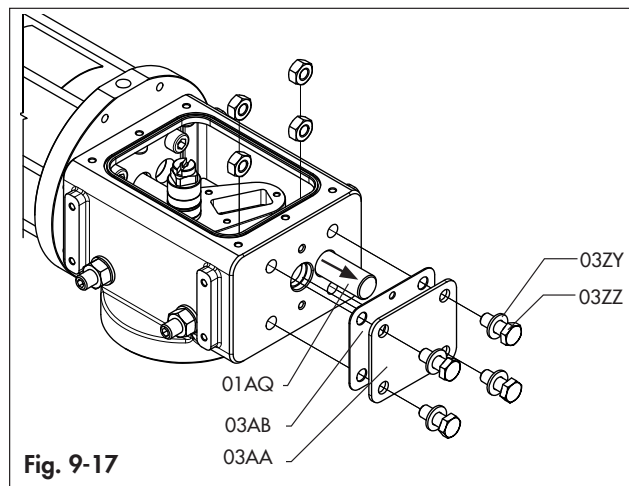

Fig. 9-16

The yoke is now separated by the sliding block and it is possible to rotate it in the power module side direction allowing access to the center body. In case of Double Acting actuator it is possible to slightly pressurize Port 4 in order to move the sliding block and provide the required space to the yoke.

- Remove the screws (03ZZ), the washers (03ZY) and the nuts (03ZX) from the double acting closing module. (Fig. 9-17).
- Remove the plate (03AA) and the gasket (03AB).
- The guide bar (01AQ) is now free and it is possible to remove it by sliding it aside.



- Remove the yoke (01AN). Carefully remove also the lower sliding block (01AR) from the yoke lower wing, the sliding plates (01AS) and the thrust bearing (01YV). (Fig. 9-18).

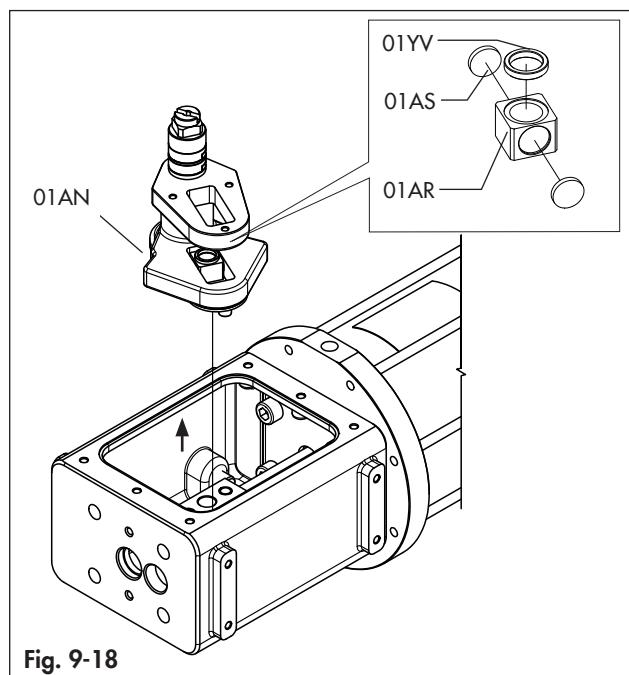

- Unscrew the screw (01YX) inside the sliding block (01AF) (Fig. 9-19).
- Push down the pin (02AI) until it falls inside the housing (Fig. 9-19).

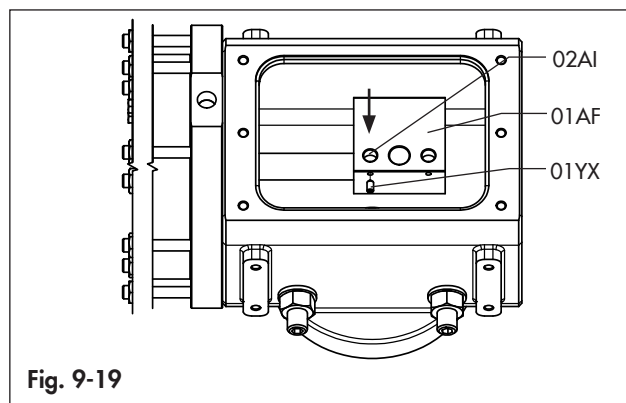

- Remove the screws (02ZZ) (Fig. 9-20).

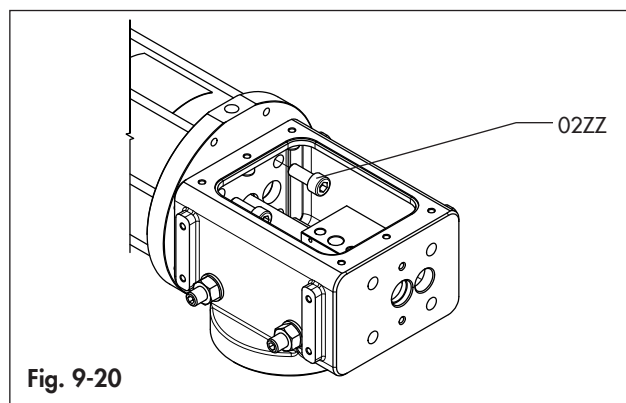

- Remove the power module and the sliding block (01AF) (Fig. 9-20).

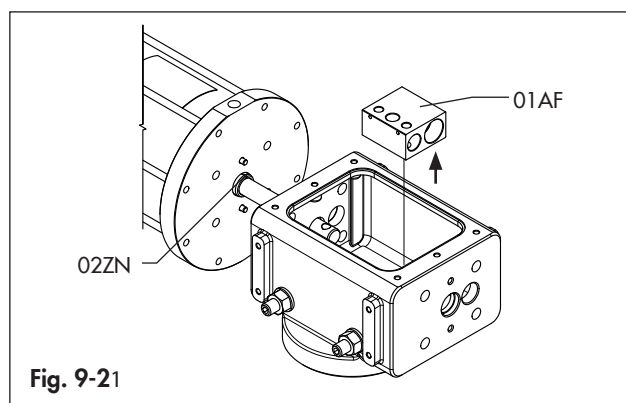

i Note

The component (02ZN), may result loosen since they are not fixed. (Fig. 9-21)

9.3.4 Power module disassembly

Operate with the power module in a vertical position as shown in Fig. 9-25.

⚠ WARNING

Risk of personal injury due to compressed springs.

End flanges are under tension due to compressed springs.

- ➔ Before starting any work on the actuator disconnect all pneumatic / hydraulic / electrical supplies from the actuator and exhaust the pressure from the power module.
- ➔ Make sure that the actuator is in the fail position before disassembling.
- ➔ Make sure that the stopper screws (02) have been correctly removed as per section 9.2.1.

ⓘ NOTICE

Risk of cylinder damage due to incorrect handling.

The internal surface of the cylinder (02AC) may be damaged permanently if not handled carefully.

- ➔ Disassemble the piston (02AE) making sure not to scratch the internal surface of the cylinder (02AC).

ⓘ NOTICE

Risk of components damage due to incorrect disassembly.
During disassembly the end flange can be damaged due to uneven force generated by compressed springs.

- ➔ Remove the end flange (02AB) as shown in Fig. 9-22 keeping a constant distance ($A = B$) between the cylinder and the end flange interface.
- ➔ Follow the specified sequence shown in Fig. 9-23.
- ➔ Observe the specified number of turns for nuts according to Table 9-2.

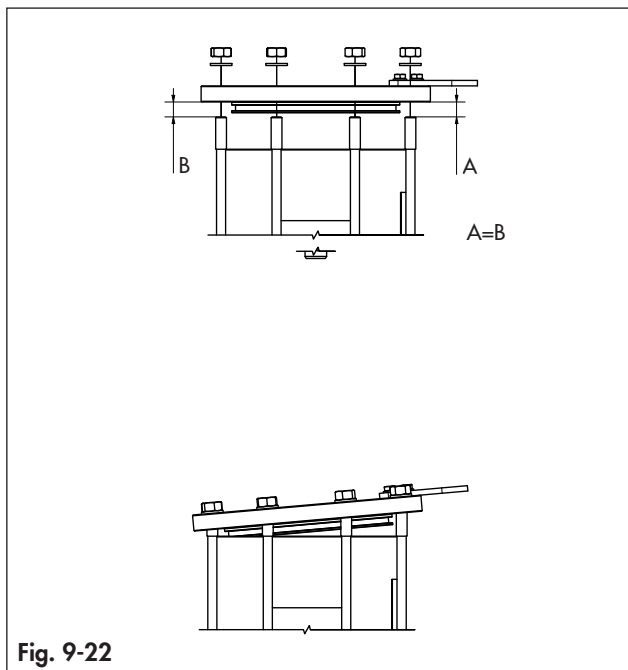

Fig. 9-22

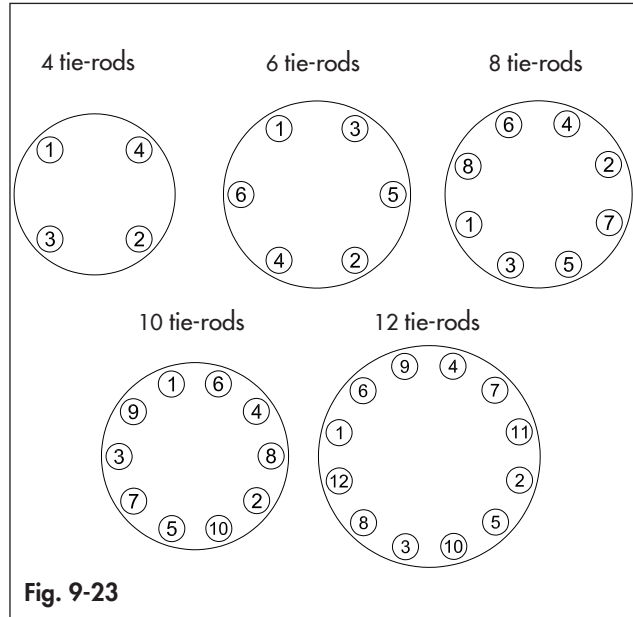

Fig. 9-23

Table 9-2

ACTUATOR MODEL	NUMBER OF TURNS
AT-HDC 035	2 ÷ 4 turns
AT-HDC 045	
AT-HDC 055	4 ÷ 6 turns
AT-HDC 065	

1) Pneumatic module without spring

- Remove the sleeve (02ZN). (Fig. 9-24).

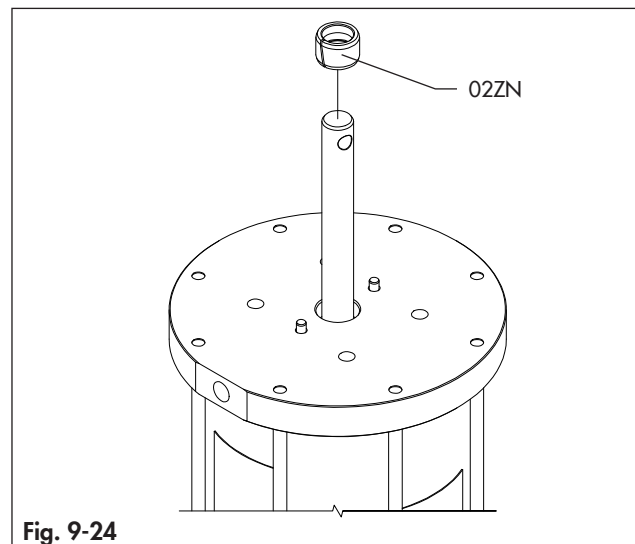

Fig. 9-24

- Slowly unscrew the nuts (02ZE), the washers (02ZP) and tie-rods (02AQ) and remove the end flange (02AB) (Fig. 9-25).

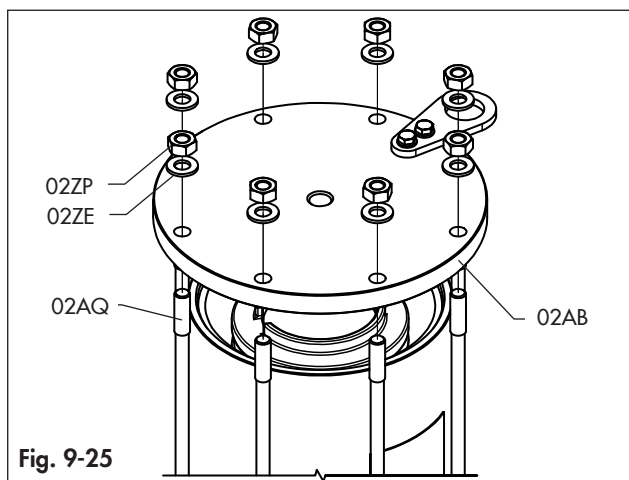

Fig. 9-25

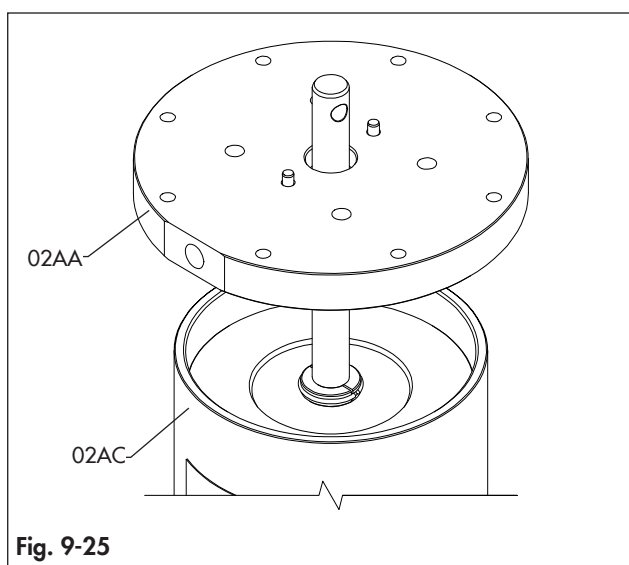

Fig. 9-25

- Remove the piston (02AE) together with the shaft (02AD) from the cylinder (02AC) by applying a small force on the stem. (Fig. 9-26).

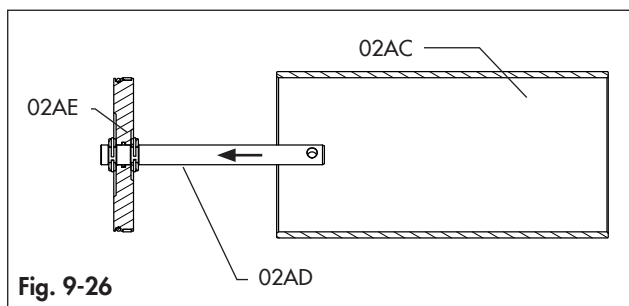

Fig. 9-26

2) Pneumatic module with spring

- Slowly unscrew the nuts (02ZE), the washers (02ZP), the tie-rods (02AQ) and remove the end flange (02AB) (Fig. 9-25). Follow the sequence as shown in figure 9-22 and 9-23. The power module contains a preloaded spring which will push the end flange 3-4 mm upwards.
- When the nuts have been unscrewed the number of turns stated in Table 9-2, if the end flange is still pushed by the

spring, then stop the disassembly and restore all the nuts. Contact Air Torque before proceeding further.

- Remove the preloaded spring unit Fig 9-27.

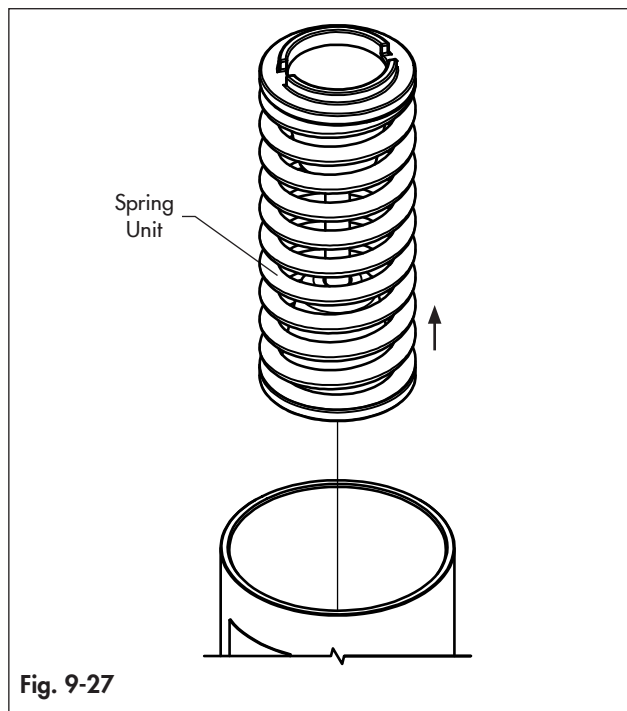

Fig. 9-27

- Remove the piston (02AE) together with the shaft (02AD) from the cylinder (02AC) by applying a small force on the stem. (Fig. 9-26).

9.3.5 Piston disassembly

- Remove the spring clip (02ZO) with a proper plier and remove the sector retainers (02AL) from the shaft (02AD). (Fig. 9-28).

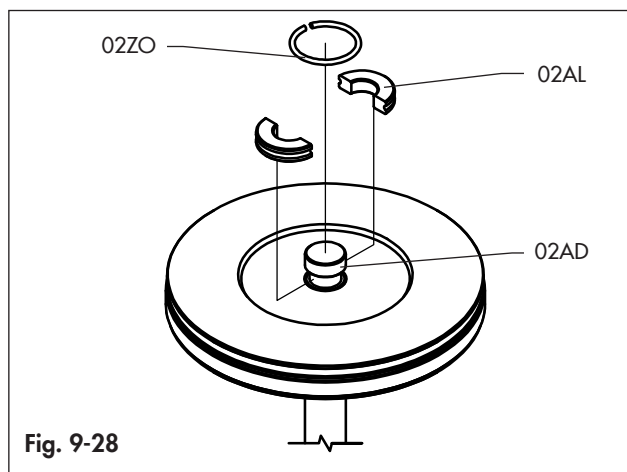

Fig. 9-28

- Remove the bearing tape (02ZG) and the o-rings (02ZT and 02ZU) from the piston (02AE). (Fig. 9-29).

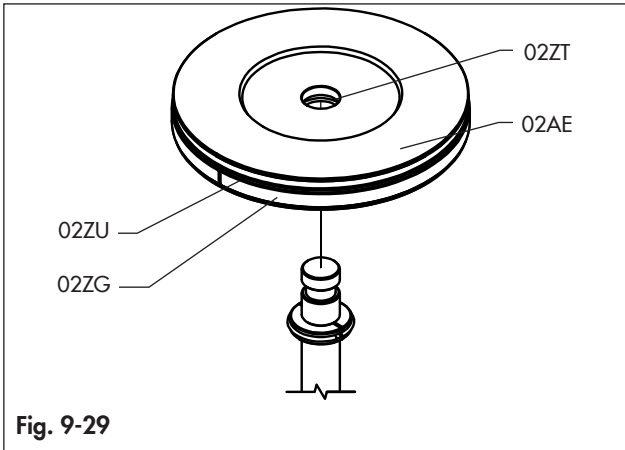

Fig. 9-29

9.4 Service operations

- Inspect and clean every single component.
- Inspect, clean and replace bolts and nuts, if needed.
- Discard and replace the damaged soft components available in the spare parts kit.
- ➔ Refer to the spare parts kit data sheet HDC50100E and to the Rubber products storage instructions T 3.3.3.1 EN.
- Clean and lubricate every o-ring housing.
- Lubricate every o-ring during reassembling.
- ➔ Refer to the data sheet HDC50100E for the correct lubricant type.
- Clean and lubricate every sliding component and its housing.
- ➔ Refer to the section 15.3 'Lubricants'.
- Clean the relief valve (C097) lower bore over the Central module housing (01AA) bottom side making sure it is not obstructed. (Fig. 9-30).

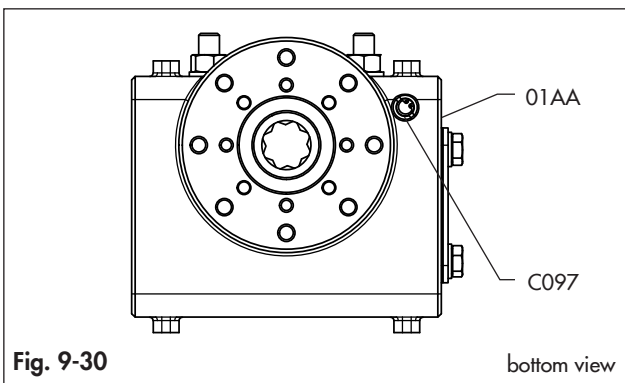

Fig. 9-30

bottom view

- Where required during the reassembly apply the correct threadlocker.
- ➔ Refer to the threadlocker types indicated in section 15.4.

9.5 Reassembly

NOTICE

Risk of actuator damage due to the use of unsuitable lubricants.

The lubricants to be used depend on the actuator material and operating temperatures. Unsuitable lubricants may corrode and damage the surface.

➔ Only use lubricants approved by AIR TORQUE indicated in section 15.3.

9.5.1 Piston reassembly

- Clean, inspect, lubricate the related housings and place the bearing (02ZG) and the o-rings (02ZT and 02ZU).
- Keeping the shaft (02AD) in a vertical position, assemble the piston (02AE) by means of proper lifting equipment. The piston must be assembled as shown in Fig. 9-31 with the bearing placed on the longer side of the stem.
- Clean, inspect, lubricate the related housings and place the bearing (02ZG) and the o-ring (02ZU).

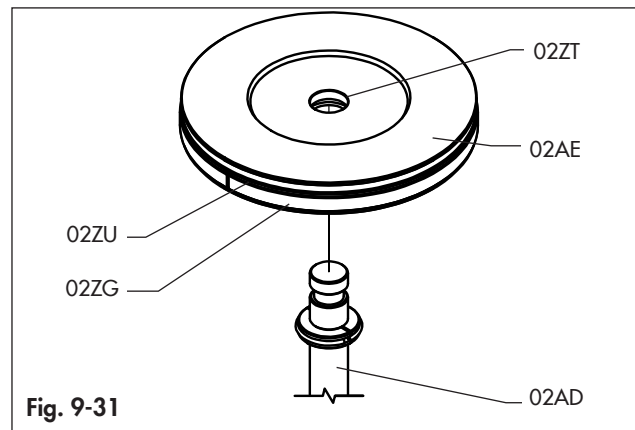

Fig. 9-31

- Place the sectors (02AL) in the related housings and fix them in position with the spring clip (02ZO) with a proper plier. (Fig. 9-32).

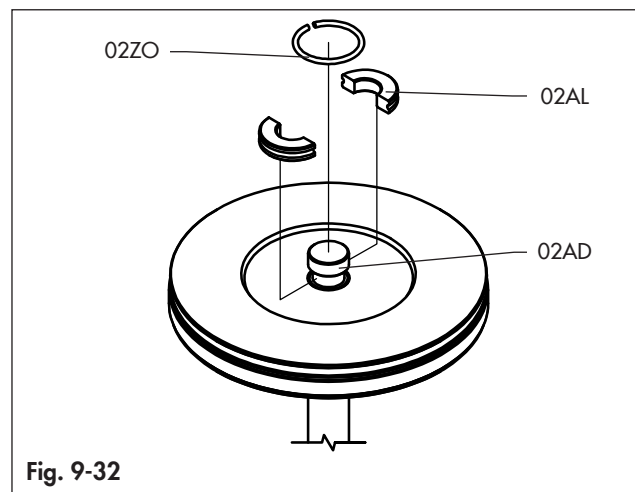

Fig. 9-32

9.5.2 Power module reassembly

NOTICE

Risk of components damage due to incorrect reassembly.
During disassembly the end flange can be damaged due to uneven force generated by compressed springs.

- Assemble the end flange as shown in Fig. 9-22 keeping a constant distance ($A = B$) between the cylinder and the end flange interface.
- Observe the specified sequence shown in Fig. 9-23.

NOTICE

Risk of cylinder damage due to incorrect handling.
The internal surface of the cylinder (02AC) may be damaged permanently if not handled carefully.

- Do not leave any external body such as brush bristles into the cylinder (02AC) while lubricating the internal surface.
- Assemble the piston (02AE) making sure not to scratch the internal surface of the cylinder (02AC).

1. Pneumatic module without spring

- Clean, inspect, lubricate the related housings and replace the o-rings (02ZW, 02ZV and 02ZS). (Fig. 9-33).

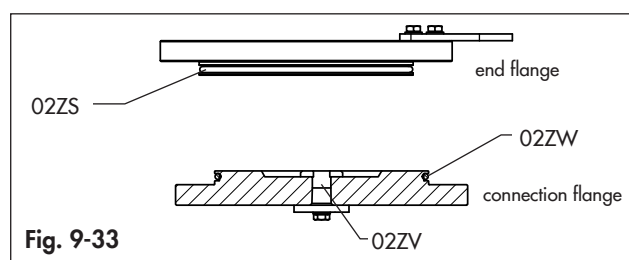

- Lubricate the internal surface of the cylinder (02AC).
- Lubricate the stem (02AD).
- Lift and place the piston assembly in the cylinder: engage carefully the piston (02AE) into the cylinder (02AC). (Fig. 9-34).

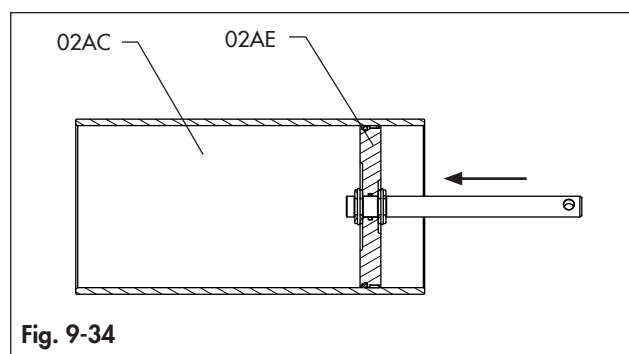

- Carefully lift the flange (02AA) and carefully engage the stem (02AD).

- Place the flange in position on the cylinder (02AC). (Fig. 9-35).

Pay attention to the air supply connection orientation. Reassemble the flange with the same orientation originally provided by Air Torque.

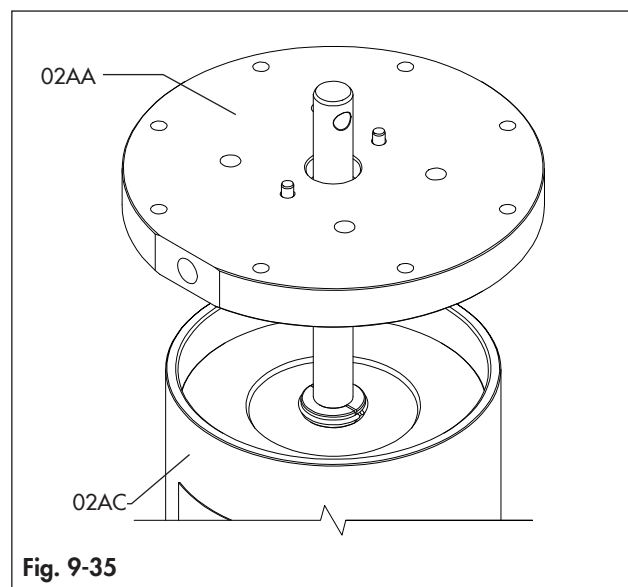

- Place the end flange (02AB) in position on the cylinder (02AC). (Fig. 9-36).

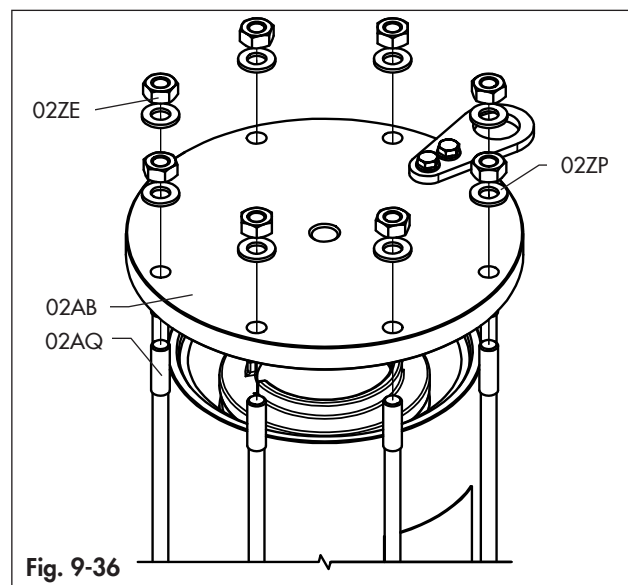

- Apply the threadlocker Loxeal 83•21 or equivalent and the tie-rods (02AQ), the washers (02ZP) and nuts (02ZE).
- Refer to section 15.2 for correct tightening torques and sequence.

2. Pneumatic module with spring

- Clean, inspect, lubricate the related housings and replace the o-rings (02ZW, 02ZV and 02ZS). (Fig. 9-33).
- Lubricate the internal surface of the cylinder (02AC).
- Lubricate the stem (02AD).

- Lift and place the piston assembly in the cylinder: engage carefully the piston (02AE) into the cylinder (02AC) (Fig. 9-33).
- Carefully lift the flange (02AA) and carefully engage the stem (02AD) (Fig 9-35).
- Place the spring preloaded unit inside the cylinder by paying attention to match its proper housing (Fig 9-37).
- Place the flange (02AB) in position on the cylinder (02AC). The end flange will remain detached from the cylinder (02AC) due to the spring preload. (Fig 9-36).
- Apply the threadlocker Loxeal 83•21 or equivalent and tie-rods the tie-rods (02ZK).

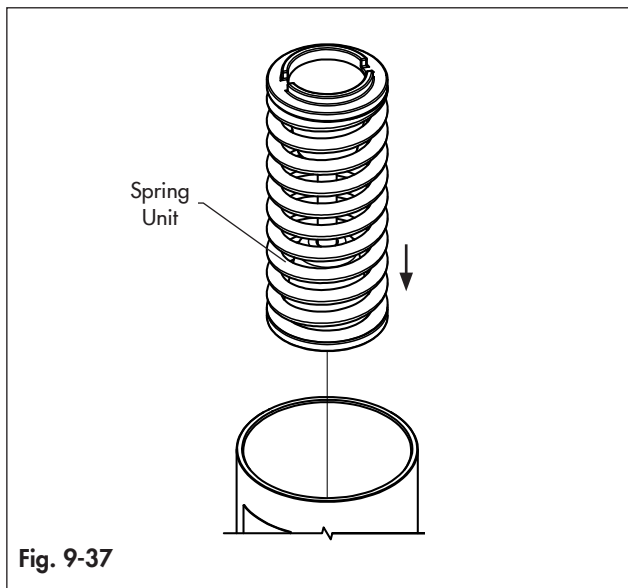

Fig. 9-37

Pay attention to the air supply connection orientation. Reassembly the flange with the same orientation originally provided by Air Torque.

- ➔ Refer to section 15.2 for correct tightening torques and sequence.
- Apply the threadlocker Loxeal 83•21 or equivalent and screw the nuts (02ZE) and washers (02ZP). (Fig. 9-22 and Fig. 9-23).
- ➔ Refer to section 15.2 for correct tightening torques and sequence.

9.5.3 (W) Welded central module configuration reassembly

In case of casted configuration please refer to chapter 9.4.5

9.5.3.1 Central module reassembly

- Lift and align the Power module to the Central module.

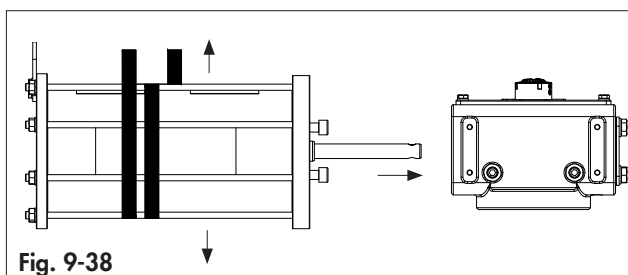

Fig. 9-38

- Make sure the components (02ZN), if any, and the pins (02ZF) are in the correct position, as per Fig. 9-39.

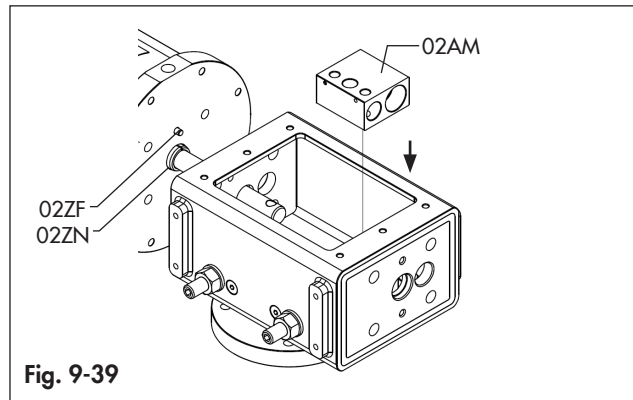

Fig. 9-39

- Insert the shaft (02AD) into the Central module and into the sliding block (01AF). (Fig. 9-40) (Fig. 9-41).
- Add the pin (02AI) keeping the small machining on the upper side. When assembled in the correct position, the pin surface is aligned with the surface of the sliding block. (Fig. 9-41).
- Apply the threadlocker Loxeal 83•21 or equivalent and tighten the screw (01YX). (Fig. 9-40).

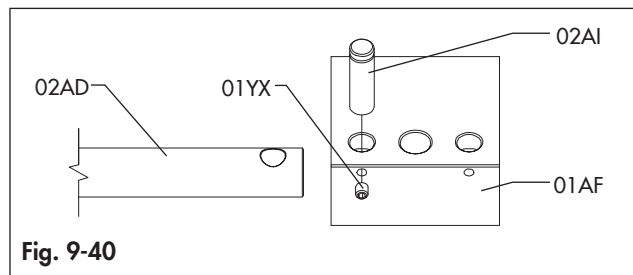

Fig. 9-40

- Apply the threadlocker Loxeal 83•21 or equivalent and tighten the bolts (02ZZ) following a cross-bolt tightening sequence at the recommended torque. (Fig. 9-41).
- ➔ Refer to section 15.2 for the correct tightening torque and sequence.

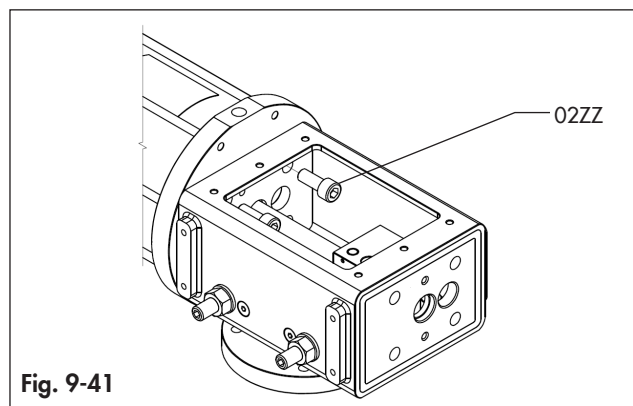

Fig. 9-41

- Clean and inspect the yoke (01AN). (Fig. 9-42).
- Assembly the lower yoke cover (01AO) and the gasket (01AU). (Fig. 9-42).
- Apply the thread locker Loxeal 83•21 or equivalent and tighten the screws (01YU). (Fig. 9-42).

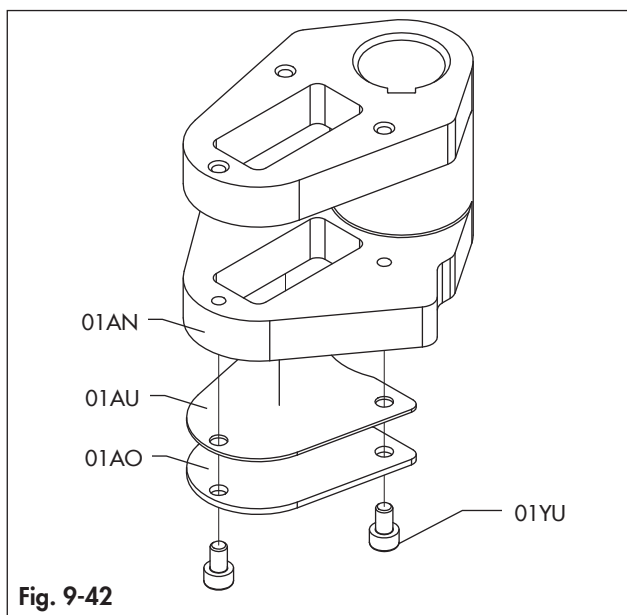

Fig. 9-42

- Assemble the lower sliding block (01AR) with the sliding plates (01AS) and the bottom thrust bearing (01YW) and place them inside the yoke lower wing. (Fig 9-43).

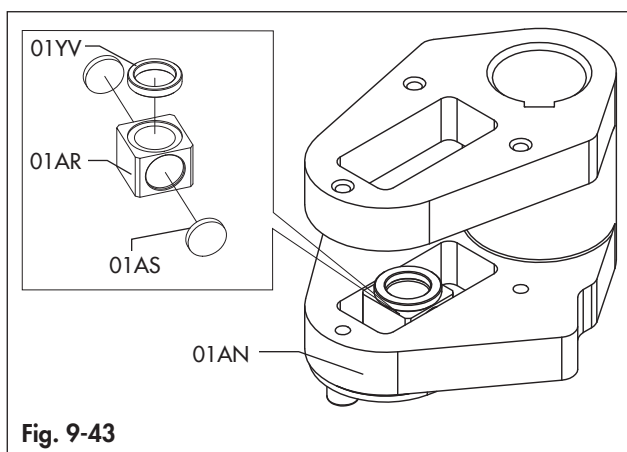

Fig. 9-43

- Place the yoke assembly inside the housing. (Fig 9-44).
- Add the guide bar (01AQ) inside the housing and through the sliding block (01AF). (Fig. 9-45).
- Add the gasket (03AB), the plate (03AA).
- Apply the thread locker Loxeal 83•21 or equivalent and tighten the screw (03ZZ), the washers (03ZY) and nuts (03ZX) (Fig. 9-44).

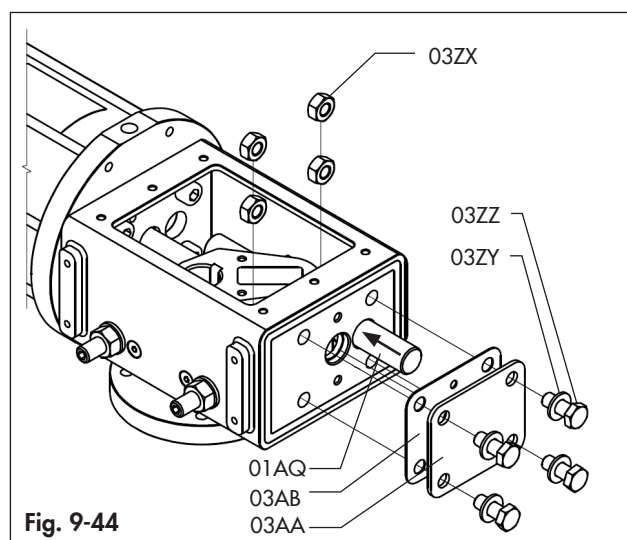

Fig. 9-44

- Clean the drive shaft, and replace the bearings (01ZA) and (01ZB). (Fig. 9-45).
- Add the key (01YY) on the drive shaft (01AH) and place it inside the housing from the bottom. (Fig. 9-45).

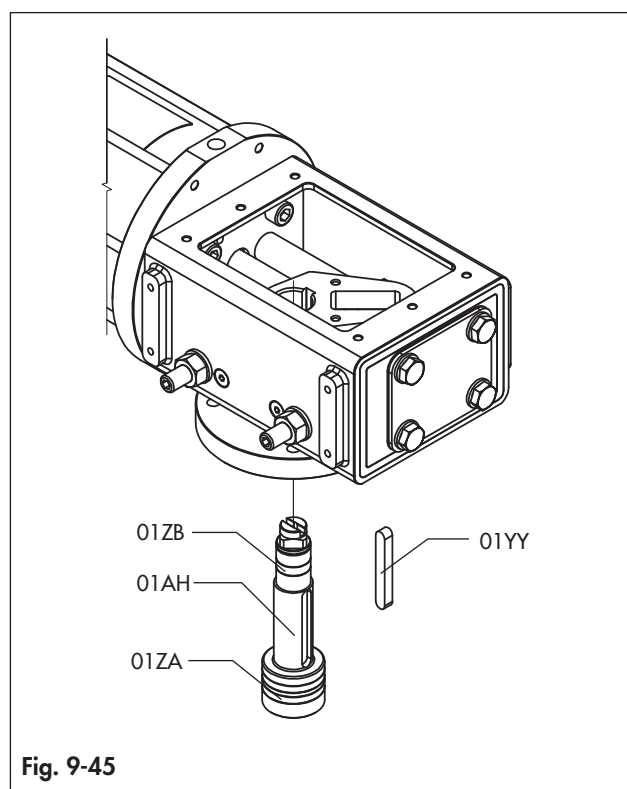

Fig. 9-45

- Align the lower sliding block hole with the sliding block hole by rotating the yoke. (Fig. 9-46).
- Place the yoke pin (01AE) inside its housing. (Fig. 9-46).
- Add the upper sliding block (01AR) the sliding plates (01AS) and the thrust bearing (01YW) on the yoke pin (01AE) inside the yoke (01AN). (Fig. 9-46).

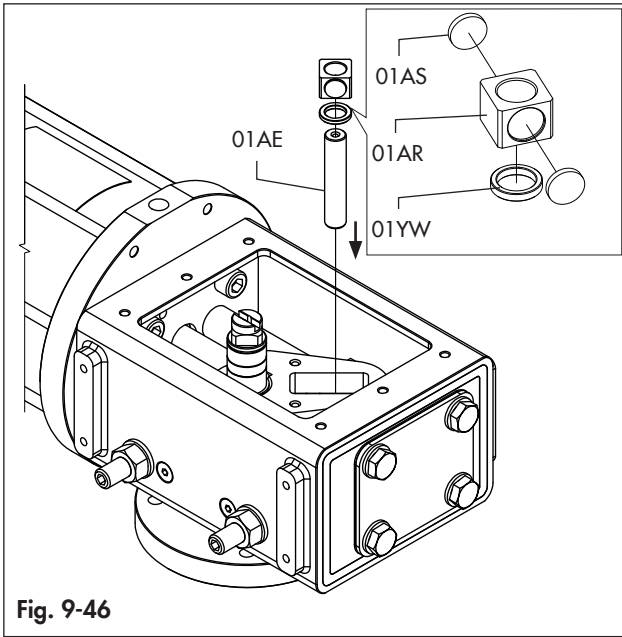

Fig. 9-46

- Lubricate the yoke mechanism.
- Add the yoke cover (01AO), the gasket (01AU) and the upper thrust bearing (01ZE) (Fig. 9-47).
- Apply the thread locker Loxeal 83•21 or equivalent and tighten the screws (01YU) (Fig. 9-47).

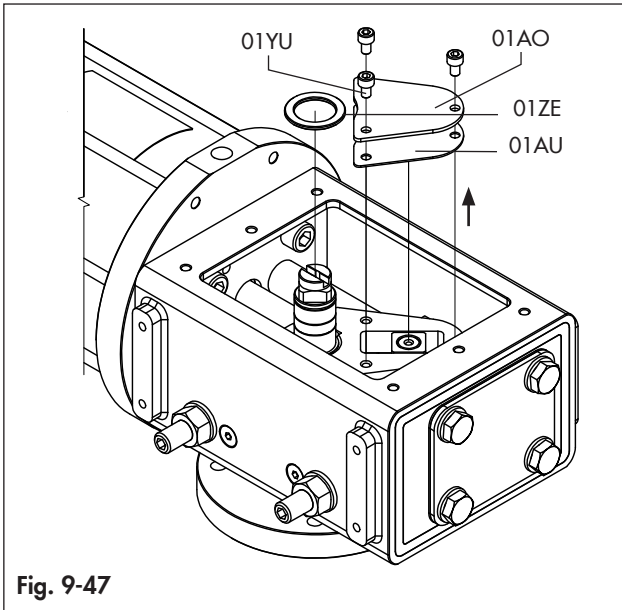

Fig. 9-47

9.5.3.2 Cover reassembly

- Replace and lubricate the o-ring (01ZF) inside the cover (01AC) (Fig. 9-48).

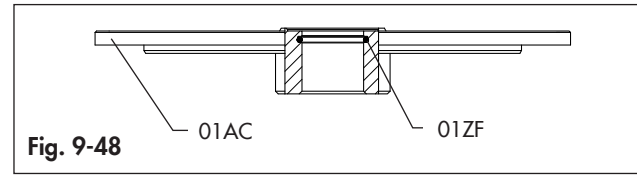

Fig. 9-48

- Place the cover (01AC) and the gasket (01AD) (Fig. 9-49).

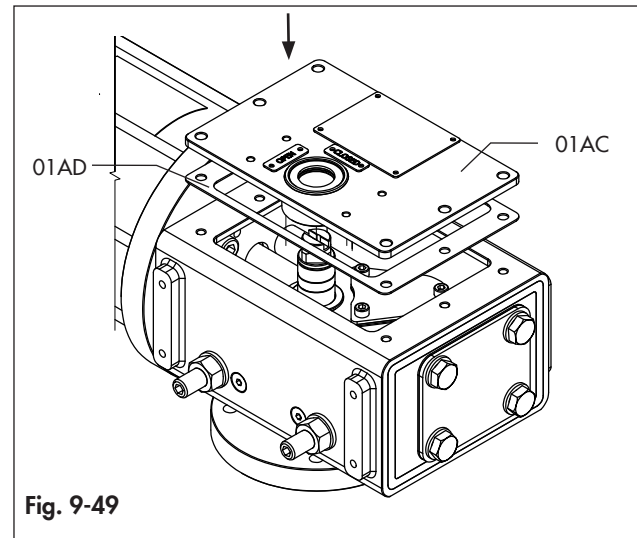

Fig. 9-49

- Apply the thread locker Loxeal 83•21 or equivalent and tighten the screws (01ZR) and washers (01ZQ). (Fig. 9-50).
- Add the upper thrust bearing (01ZE), the washer (01ZD) and the spring clip (01ZC) on the drive shaft. In case of any difficulty when placing the spring clip it is possible to push upwards the drive shaft by applying a light force from the bottom (Fig. 9-50).
- Add the position indicator (01ZS) and (01YT) on the drive shaft by keeping attention on the orientation. (Fig. 9-50).

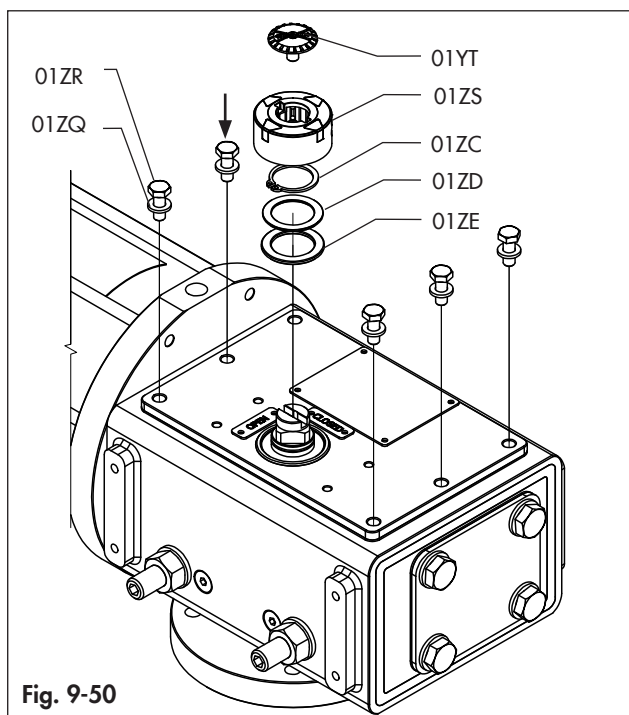

Fig. 9-50

For stroke adjustment screws reassembly please refer to chapter 9.4.6

9.5.4 (C) Casted central module configuration reassembly

9.5.4.1 Central module reassembly

- Lift and align the Power module to the Central module.

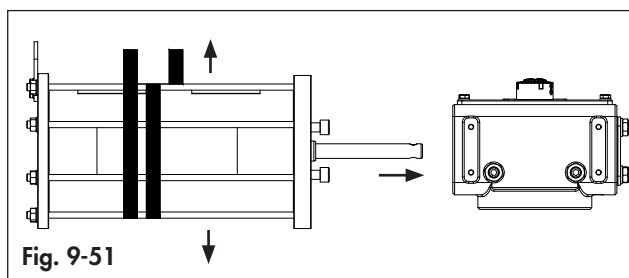

Fig. 9-51

- Make sure the components (02ZN), if any, and the pins (02ZF) are in the correct position, as per Fig. 9-52.

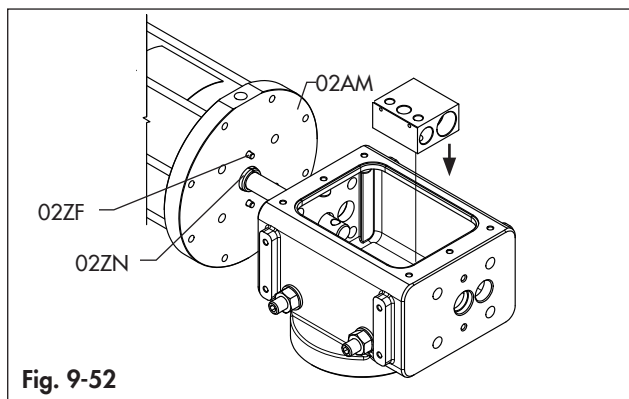

Fig. 9-52

- Insert the shaft (02AD) into the Central module and into the sliding block (01AF). (Fig. 9-53) (Fig. 9-54).
- Add the pin (02AI) keeping the small machining on the upper side. When assembled in the correct position, the pin surface is aligned with the surface of the sliding block. (Fig. 9-53).
- Apply the threadlocker Loxeal 83•21 or equivalent and tighten the screw (01YX). (Fig. 9-53).

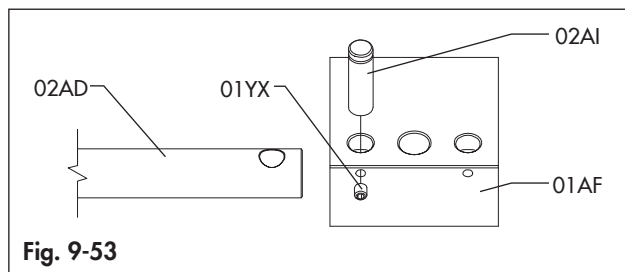

Fig. 9-53

- Apply the threadlocker Loxeal 83•21 or equivalent and tighten the bolts (02ZZ) following a cross-bolt tightening sequence at the recommended torque. (Fig. 9-54).
- ➔ Refer to section 15.2 for the correct tightening torque and sequence.

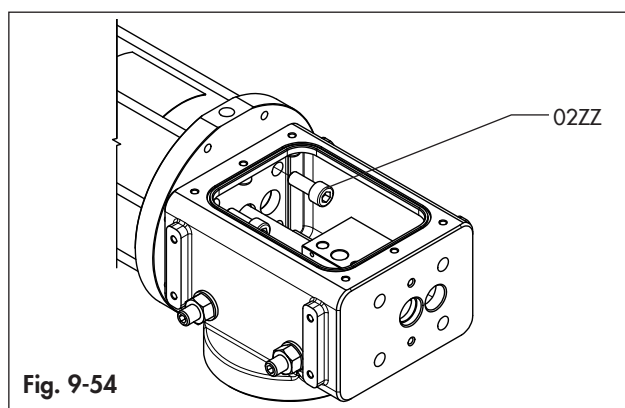

Fig. 9-54

- Clean and inspect the yoke (01AN). (Fig. 9-55).
- Assembly the lower yoke cover (01AO), the gasket (01AU) and upper (01YO) and lower (01YN) bands. (Fig. 9-55).
- Apply the thread locker Loxeal 83•21 or equivalent and tighten the screws (01YU). (Fig. 9-55).

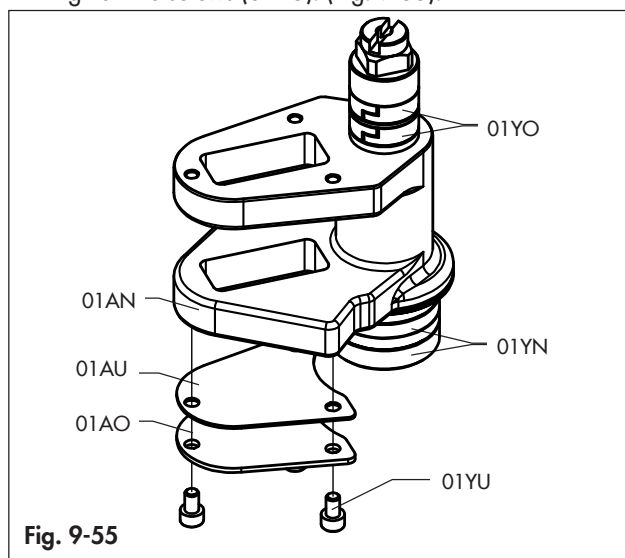
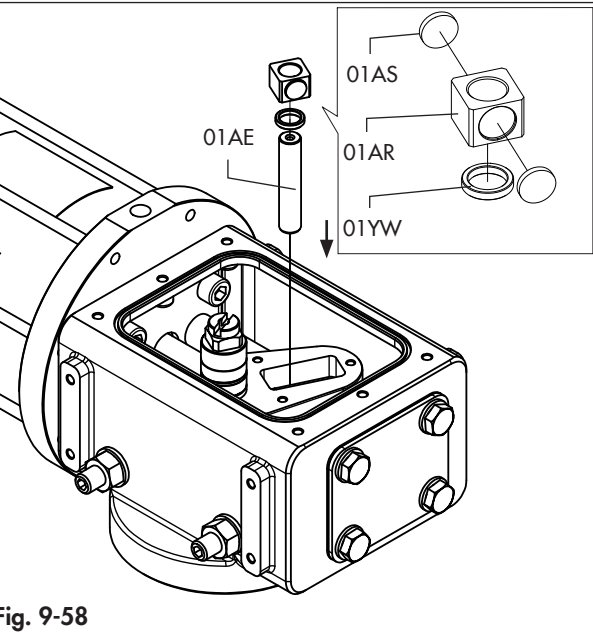
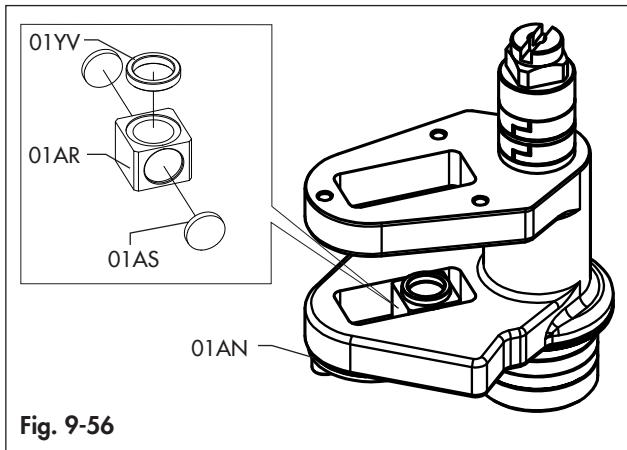
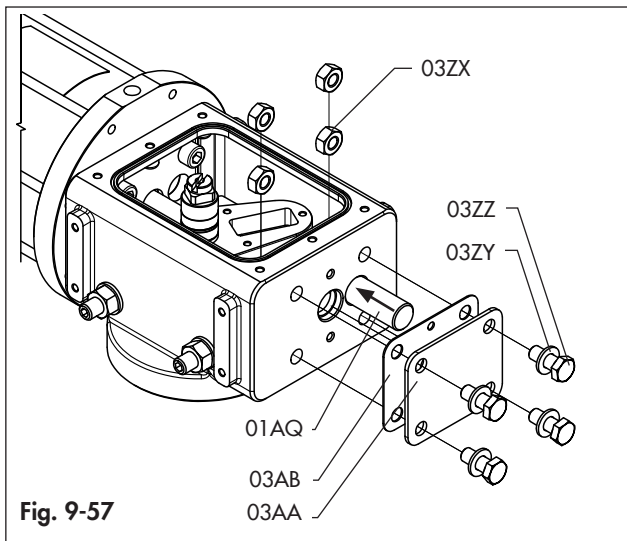

Fig. 9-55

- Assemble the lower sliding block (01AR) with the sliding plates (01AS) and the bottom thrust bearing (01YW) and place them inside the yoke lower wing. (Fig 9-56).



- Place the yoke assembly inside the housing. (Fig 9-57).
- Add the guide bar (01AQ) inside the housing and through the sliding block (01AF). (Fig. 9-57).
- Add the gasket (03AB), the plate (03AA).
- Apply the thread locker Loxeal 83•21 or equivalent and tighten the screw (03ZZ), the washers (03ZY) and nuts (03ZX) (Fig. 9-57).



- Lubricate the yoke mechanism.
- Add the yoke cover (01AO), the gasket (01AU) and the upper thrust bearing (01ZE) (Fig. 9-59).
- Apply the thread locker Loxeal 83•21 or equivalent and tighten the screws (01YU) (Fig. 9-59).

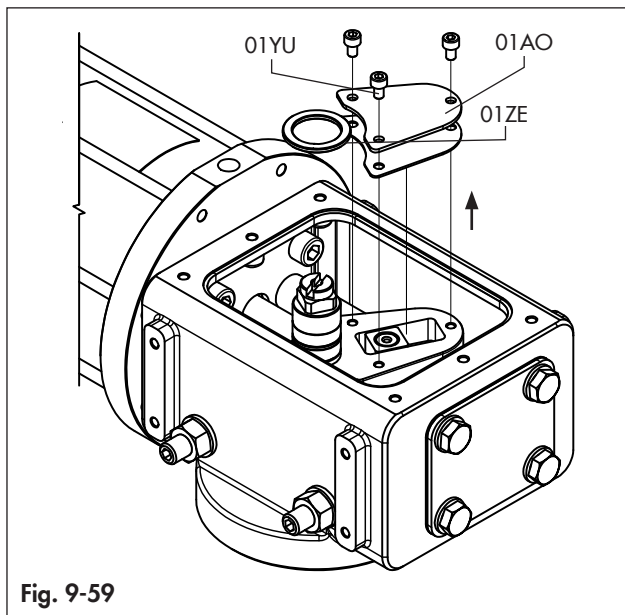

- Align the lower sliding block hole with the sliding block hole by rotating the yoke. (Fig. 9-58).
- Place the yoke pin (01AE) inside its housing. (Fig. 9-58).
- Add the upper sliding block (01AR) the sliding plates (01AS) and the thrust bearing (01YW) on the yoke pin (01AE) inside the yoke (01AN). (Fig. 9-58).

9.5.4.2 Cover reassembly

- Replace and lubricate the o-ring (01ZF) inside the cover (01AC) (Fig. 9-60).

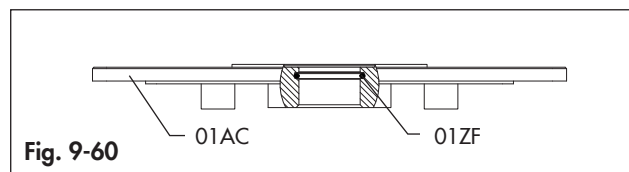

- Place the cover (01AC) and oring (01AD) (Fig. 9-61).

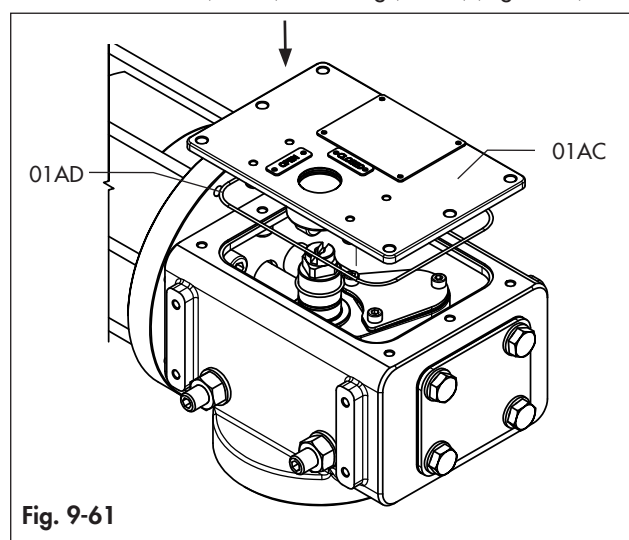

- Apply the thread locker Loxeal 83•21 or equivalent and tighten the screws (01ZR) and washers (01ZQ). (Fig. 9-62).
- Add the position indicator (01ZS) and (01YT) on the drive shaft by keeping attention on the orientation. (Fig. 9-62).

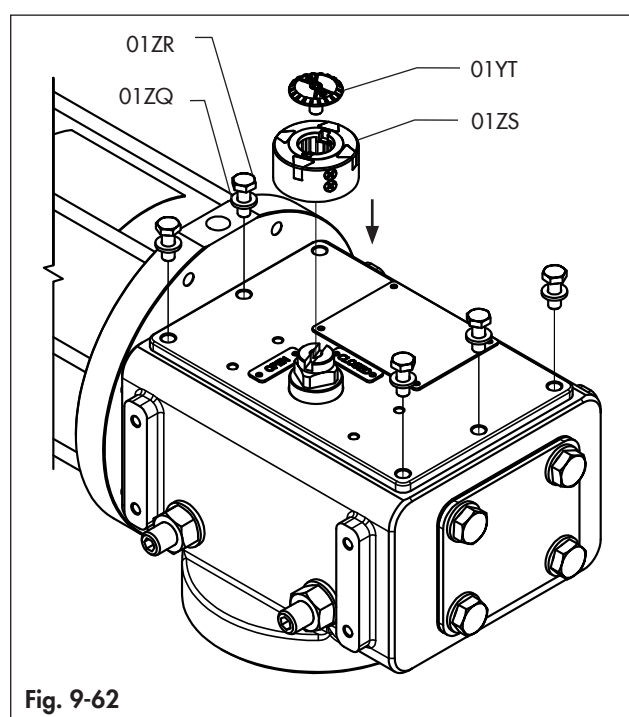

9.5.5 Stroke adjustment screws reassembly

i Note

In case of actuator with complementary parts refer to the corresponding instructions:

- Jackscrew → EB AT-HDC-JS,
- Hydraulic pump → EB AT-HDC-HP,
- Declutchable jackscrew → EB AT-HDC-JD,
- Damper → EB AT-HDC-DP.

i Note

The screws (01ZW) may have different length depending on the actuator stroking range. Make sure to link the correct adjustment screws to the actuator as reassembled.

- Add the stroke adjustment screws (01ZW), the o-ring (01YR), the washer (01ZV) and the nut (01ZU) in its proper position. (Fig. 9-63).

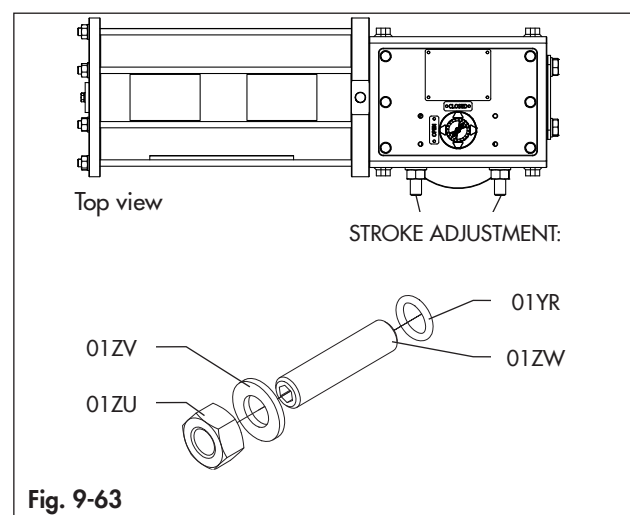

9.5.6 Stroke adjustment

1. Double acting actuators

- Progressively pressurize Port 2 to completely stroke the actuator.
- ➔ Refer to the functioning labels to correctly pressurize the actuator. (Section 2.2).
- Screw or unscrew the screw (01ZW) adjacent to the power module position to adjust to the stroke end.
- Discharge the actuator from Port 2 and progressively pressurize Port 4 to completely stroke the actuator.
- Screw or unscrew the screw (01ZW) on the opposite side of the power module to adjust the stroke end.
- If the stroke is not adjusted correctly in both end positions, repeat the steps above.
- When the stroke is correctly adjusted, completely tighten the nut (01ZU).

2. Single acting fail close actuators

2.1 Closed position (0°)

- Loosen the nut (01ZU) of the RIGHT adjustment screw.
- Slightly pressurize Port 2 to compress the spring removing the load from the screw (01ZW).
- ➔ Refer to the functioning labels to correctly pressurize the actuator. (Section 2.2).
- Screw or unscrew the screw (01ZW) to adjust the stroke in the closed position.
- Release the pressure from the power module and check the actuator stroke reaching the fail close position.
- If the stroke is not adjusted correctly, repeat the steps above.
- When the stroke is correctly adjusted, completely tighten the nut (01ZU) keeping in position the screw (01ZW) with a proper tool.

2.2 Open position (90°)

- Loosen the nut (01ZU) of the LEFT adjustment screw.
- Screw or unscrew the screw (01ZW) to adjust the stroke.
- Progressively pressurize Port 2 to completely stroke the actuator reaching the open position.
- ➔ Refer to the functioning labels to correctly pressurize the actuator. (Section 2.2).
- Verify the stroke adjustment and release the pressure from the power module reaching the fail close position.
- If the stroke is not adjusted correctly, repeat the steps above.
- When the stroke is correctly adjusted, proceed as follows to completely tighten the nut (01ZU):
 - slightly pressurize Port 2 to slowly rotate the actuator reaching the open position,
 - keep the actuator in the open position to make sure the adjustment screw (01ZW) do not fasten out of position.
 - completely tighten the nut (01ZU) keeping in position the screw (01ZW) with a proper tool.

3. Single acting fail open actuators

3.1 Open position (90°)

- Loosen the nut (01ZU) of the LEFT adjustment screw.
- Slightly pressurize Port 4 to compress the spring removing the load from the screw (01ZW).
- ➔ Refer to the functioning labels to correctly pressurize the actuator. (Section 2.2).
- Screw or unscrew the screw (01ZW) to adjust the stroke in the open position.
- Release the pressure from the power module and check the actuator stroke reaching the fail open position.

- If the stroke is not adjusted correctly, repeat the steps above.
- When the stroke is correctly adjusted, completely tighten the nut (01ZU) keeping in position the screw (01ZW) with a proper tool.

3.2 Closed position (0°)

- Loosen the nut (01ZU) of the RIGHT adjustment screw.
- Screw or unscrew the screw (01ZW) to adjust the stroke.
- Progressively pressurize Port 4 to completely stroke the actuator reaching the closed position.
- ➔ Refer to the functioning labels to correctly pressurize the actuator. (Section 2.2).
- Verify the stroke adjustment and release the pressure from the power module reaching the fail open position.
- If the stroke is not adjusted correctly, repeat the steps above.
- When the stroke is correctly adjusted, proceed as follows to completely tighten the nut (01ZU):
 - slightly pressurize Port 4 to slowly rotate the actuator reaching the closed position,
 - keep the actuator in the closed position to make sure the adjustment screw (01ZW) do not fasten out of position,
 - completely tighten the nut (01ZU) keeping in position the screw (01ZW) with a proper tool.

9.5.7 Mounting the actuator over the valve

- ➔ Refer to the section 5.3 'Mounting the actuator over the valve'.

10 Decommissioning

The work described in this section is only to be performed by fully trained and qualified personnel.

⚠ DANGER

Risk of bursting due to incorrect opening of pressurized equipment or components.

Pneumatic actuators are pressure equipment that may burst when handled incorrectly. Flying projectile fragments or components can cause serious injury or even death.

- Before starting any work on the actuator disconnect all pneumatic/hydraulic/electrical supplies and discharge the pressure from the actuator.

⚠ WARNING

Risk of personal injury due to compressed springs.

Spring modules are under tension due to compressed springs. Consequently, the disassembly could result in serious injury.

- Before starting any work on the actuator disconnect all pneumatic/hydraulic/electrical supplies and discharge the pressure from the actuator.
- The actuator must be in the fail position while removing the Spring module from the Central module.
- If Spring module service is necessary, contact AIR TORQUE.

⚠ WARNING

Risk of personal injury during actuator air exhaust.

In case of pneumatic cylinder configuration, the actuator is operated with air. As a result, air is exhausted during operation.

- Wear eye and hearing protection when working near the actuator.

⚠ WARNING

Crush hazard arising from moving parts.

The actuator and the valve assembly contains moving parts, which can injure hands or fingers.

- Do not touch or insert hands or finger into moving parts.
- Before starting any work on the actuator disconnect all pneumatic/hydraulic/electrical supplies and discharge the pressure from the actuator.

ⓘ NOTICE

Risk of actuator damage due to excessively high or low tightening torques.

Follow the specified torques to tighten actuator components (bolts and nuts). Tightening torques above the limits lead to parts wearing out quicker. Parts that are not tightened enough may loosen.

- Observe the specified tightening torques in section 15.2.

To decommission the actuator for service work or before removing it from the valve, proceed as follows:

- Put the valve and its accessories out of operation in a safe position. Refer to the documentation available from the valve manufacturer.
- Disconnect the pneumatic/electrical supply to depressurize the actuator. In case of single acting actuator, make sure the actuator reaches the FAIL position once depressurized.

11 Removal

The work described in this section is only to be performed by fully trained and qualified personnel.

Before removing from the valve, make sure the actuator is put out of operation. Refer to section 10 'Decommissioning'.

⚠ DANGER

Risk of bursting due to incorrect opening of pressurized equipment or components.

Pneumatic actuators are pressure equipment that may burst when handled incorrectly. Flying projectile fragments or components can cause serious injury or even death. Before working on the actuator:

- ➔ Before starting any work on the actuator disconnect all pneumatic/hydraulic/electrical supplies and discharge the pressure from the actuator.

⚠ WARNING

Risk of personal injury during actuator air exhaust.

In case of pneumatic power cylinder configuration, the actuator is operated with air. As a result, air is exhausted during operation.

- ➔ Wear eye and hearing protection when working near the actuator.

⚠ WARNING

Risk of personal injury due to compressed springs.

Spring modules are under tension due to compressed springs. Consequently, the disassembly could result in serious injury.

- ➔ Before starting any work on the actuator disconnect all pneumatic/hydraulic/electrical supplies and discharge the pressure from the actuator.
- ➔ The actuator must be in the fail position while removing the Spring module from the Central module.
- ➔ If Spring module service is necessary, contact AIR TORQUE.

⚠ WARNING

Crush hazard arising from moving parts.

The actuator and the valve assembly contains moving parts, which can injure hands or fingers.

- ➔ Do not touch or insert hands or finger into moving parts.
- ➔ Before starting any work on the actuator disconnect all pneumatic/hydraulic/electrical supplies and discharge the pressure from the actuator.

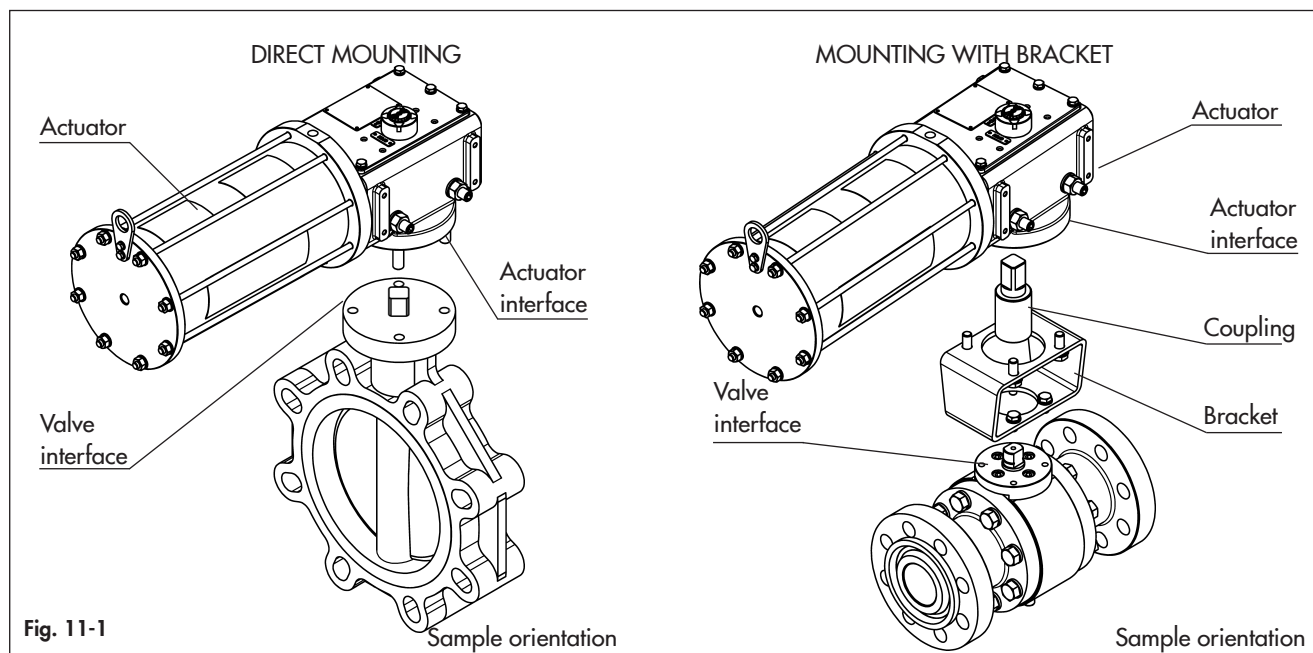

Proceed as follows to remove the actuator from the valve referring to Fig. 11-1, making sure to not expose the plant to any risk:

- Disconnect any electrical/pneumatic/hydraulic power supply from the actuators and make sure the actuator itself is depressurized.
- Disconnect all electrical wirings of the control or signal devices, if any.
- ➔ Refer to the control or signal devices documentation for safe disassembly.

- Remove the control or signal devices, if any.
- Remove the bolts and nuts from the valve flange and remove the actuator from the valve.
- Remove the coupling.
- Remove the bracket from the actuator, if any.
- ➔ Refer to the control or signal devices documentation for safe disassembly.

12 Repairs

If the actuator does not function properly according to how it was originally sized or does not function at all, it is defective and must be repaired or replaced.

⚠ NOTICE

Risk of actuator damage due to incorrect repair work.

- *Do not perform any repair work on your own.*
 - *Contact AIR TORQUE (aftersales@airtorque.it) for repair work.*
-

13 Disposal

At the end of their life cycle AIR TORQUE actuators can be disassembled and disposed sorting the components by the different materials.

→ Observe local, national and international refuse regulations.

All materials have been selected in order to ensure minimal environmental impact, health and safety of personnel during their installation and maintenance, provided that, during use, they are not contaminated by hazardous substances.

Oil, grease and electric components may require special treatment before disposal.

→ Contact waste management companies and/or local authorities.

⚠ WARNING

Risk of personal injury due to compressed springs.

Spring modules are under tension due to compressed springs. Consequently, the disassembly could result in serious injury.

→ *If Spring unit disposal is necessary, contact AIR TORQUE.*

The disposal is to be performed by fully trained and qualified personnel only.

- Decommission and remove the actuator (section 10 and section 11).
- Create a large area around the actuator in order to work in safe conditions without obstacles that can interfere with the disposal operation.
- Dismantle the actuator sorting the components by the different materials.

14 Certificates

The following certificates and documents are available from AIR TORQUE:

- EU Declaration of Conformity,
- ATEX Directive 2014/34/EU,
- SIL Certificate,
- Machine Directive 2006/42/EC,
- IP67 Degree of protection,
- UKCA certification.



AIR TORQUE

AIR TORQUE S.p.A.
 via dei Livelli di Sopra, N° 8/11
 24060 Costa di Mezzate (Bg) Italy
 Tel.: +39 035 682299
 Fax: +39 035 687791
 E-mail: info@airtorque.it

Doc. n° EDCHDCE

Issued: 10/2021 - Pag: 1/1

EU / UK DECLARATION OF CONFORMITY

In accordance with
Machinery Directive 2006/42/EC and U.K. Reg. S.I. 2008 No.1597 (as amended)
Atex Directive 2014/34/EU and U.K. Reg. S.I. 2016 No.1107 (as amended)
Pressure Equipment Directive (PED) 2014/68/EU and U.K. Reg. S.I. 2016 No.1105 (as amended)
 We: AIR TORQUE S.p.A. Via dei Livelli di Sopra, 8/11 - 24060 Costa di Mezzate (BG) Italy declare:

Machinery Directive 2006/42/EC (Art. 13) and U.K. Reg. S.I. 2008 No.1597 (as amended)

Declaration of incorporation of the partly completed machine (Annex II part B)

With reference to the Machinery Directive 2006/42/EC (Art. 2 point g) and U.K. Reg. S.I. 2008 No.1597 (as amended) (Part 2 point 6), the pneumatic actuators produced by Air Torque Spa listed below can be classified as "Partly completed machine". We hereby declare that the products specified below meet the basic health and safety requirements.

Before the actuators are put into operation, the machine into which the actuators will be installed, shall fulfill with the requirements of the Directive 2006/42/EC and U.K. Reg. S.I. 2008 No.1597 (as amended).

The essential requirements are applied in compliance with the following points of the Machinery Directive and U.K. Regulation:

1.1.3, 1.1.5, 1.2.1, 1.3.2, 1.3.4, 1.3.7, 1.3.8, 1.3.8.1, 1.4.1, 1.4.2.1, 1.5.1, 1.5.2, 1.5.3, 1.5.4, 1.5.7, 1.5.8, 1.6.1, 1.7.2, 1.7.3, 1.7.4

Description of the product line: Pneumatic/Hydraulic compact actuators AIR TORQUE AT-HDC Series

Type: Double acting "D" and Spring return "S".

Actuator models: AT-HDC series

Serial number: Each Air Torque actuator has a serial number for traceability.

For the use, installation and maintenance of the actuators described above, see the related manual instructions.

Atex Directive 2014/34/EU and U.K. Reg. S.I. 2016 No.1107 (as amended)

The pneumatic actuators produced by Air Torque Spa (AT-HDC Series) are designed, produced and classified according to Atex Directive 2014/34/EU and U.K. Reg. S.I. 2016 No.1107 (as amended), (see actuator label and safety instructions); their use in areas with potentially explosive atmosphere is subject to the classification indicated on the label and in compliance with the relevant ATEX safety instructions.

Product marking (AT-HDC Series)

Execution L, S

Group I (Mine) UK CE Ex I M2 Ex h I Mb X
 Group IIB (Gas) UK CE Ex II 2 G Ex h IIB T6 ... T5 Gb X
 Group IIIC (Dust) UK CE Ex II 2 D Ex h IIIC T85°C ... T95°C Db X

Group I (Mine) UK CE Ex I M2 Ex h I Mb X
 Group IIC (Gas) UK CE Ex II 2 G Ex h IIC T6 ... T5 Gb X
 Group IIIC (Dust) UK CE Ex II 2 D Ex h IIIC T85°C ... T95°C Db X

Execution H

UK CE Ex I M2 Ex h I Mb X
 UK CE Ex II 2 G Ex h IIB T6 ... T3 Gb X
 UK CE Ex II 2 D Ex h IIIC T85°C ... T165°C Db X

UK CE Ex I M2 Ex h I Mb X
 UK CE Ex II 2 G Ex h IIC T6 ... T3 Gb X
 UK CE Ex II 2 D Ex h IIIC T85°C ... T165°C Db X

Compliance has been verified on the basis of the requirements of the standards or normative documents indicated below:

EN 1127-1:2019

EN 15714-3:2009

EN 15714-4:2009

EN 80079-36:2016

EN 80079-37:2016

Technical file: **ATX21AT-HDC**
 Technical file: **UKX21AT-HDC**

Notified body (EU): **INERIS (0080)**
 Approved body (UK): **EUROFINS E&E CML Limited (2503)**

Pressure equipment directive (PED) 2014/68/EU and U.K. Reg. S.I. 2016 No.1105 (as amended)

Unless otherwise specified, the power cylinders of the pneumatic actuators AT-HDC Series produced by AIR TORQUE S.p.A. are designed according to the criteria of Article 1 paragraph 2. j) ii) and they are suitable to be operated with Group 2 and Group 1 fluids provided that the fluids are compatible with internal parts.

Therefore, according to Article 1 paragraph 2. j) ii) of the 2014/68/EU directive and Part 1, section 4, schedule 1, paragraph 1. j) ii) of U.K. Regulation S.I. 2016 No. 1105 (as amended), the power cylinders are not to be considered as pressure equipment. Only under customer request, the power modules can be designed, produced and certified according to Module H of the pressure Equipment directive 2014/68/EU or UK Regulation S.I. 2016 No. 1105 (as amended).

Signed:

Name: *A. Marinoni*

Position: Managing Director I Design and Quality Manager

AIR TORQUE S.p.A. - Italy

This data sheet is property of AIR TORQUE S.p.A Costa di Mezzate - Italy and all rights of use and reproduction are reserved.
 Due to continuous development product data is subject to change without prior notice.

Tab. n° 00_MASTRO MN02

15 Annex

15.1 Tools

15.1.1 Tools list

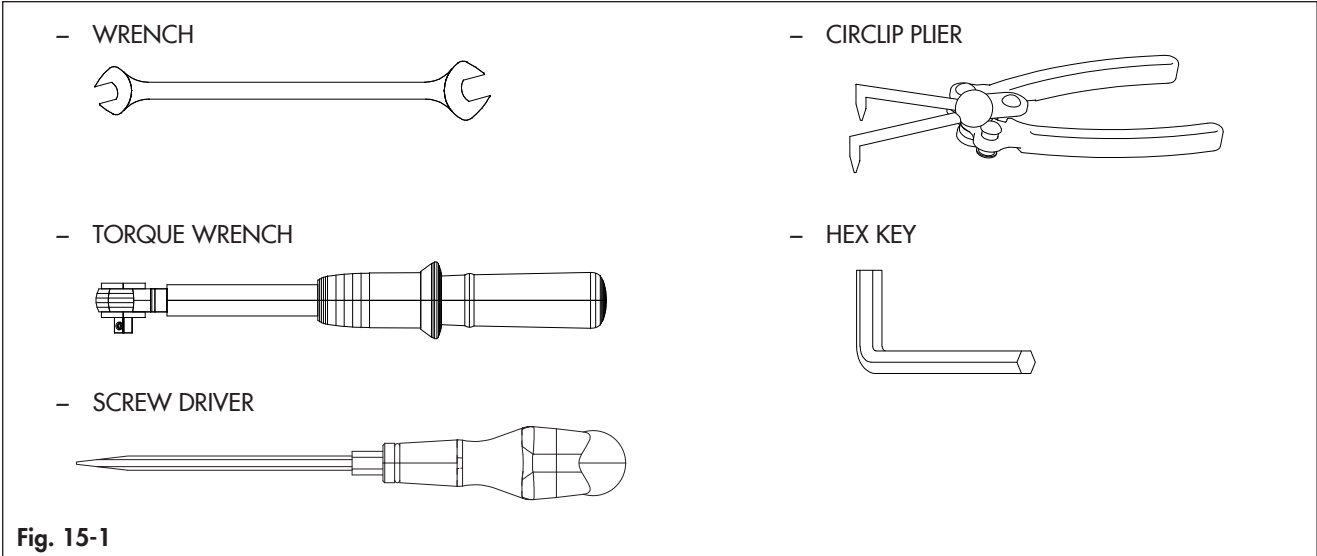

15.1.2 Tools dimensions

Table 15-1: Wrench size (mm)

ACTUATOR MODEL	POWER MODULE			CENTRAL MODULE			
	PART NUMBER						
	02ZR	02ZM	02ZE	01ZU	01ZR	03ZZ	03ZX
AT-HDC 035	21	13	13	19	10	16	17
AT-HDC 045	21	13	13	19	10	16	17
AT-HDC 055	30	17	17	27	13	24	24
AT-HDC 065	30	17	17	27	13	24	24

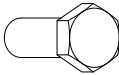

Table 15-2: Hex key size (mm)

ACTUATOR MODEL	POWER MODULE			CENTRAL MODULE			
	PART NUMBER						
	02ZZ	02ZM	01ZW	01YP	01YU	01YX	
AT-HDC 035	8	4	6	4	4	2	
AT-HDC 045	8	4	6	4	4	2	
AT-HDC 055	14	4	8	5	4	2	
AT-HDC 065	14	4	8	5	4	2	

15.2 Tightening torques and sequences

- All the tightening torques are intended in Nm.
- Tightening torque tolerance: $\pm 10\%$.
- The tightening torques are based on a friction coefficient of 0.12 with a lubricated fixing elements (bolts or nuts) threads.
- After long operating times or use at temperatures above 80°C, the breakaway torque may be significantly higher.

Table 15-3: Tightening torques

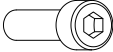
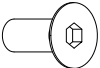
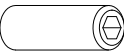
TYPE	PART NUMBER	THREAD	MATERIAL	TIGHTENING TORQUE (Nm)
	01ZR	A2-70 Stainless steel	M6	4 ÷ 5 Nm
			M8	10 ÷ 12 Nm
	01Y0	A2-80 Stainless steel	M8	10 ÷ 12 Nm
	01ZJ	A2-70 Stainless steel	M8	10 ÷ 12 Nm
			M10	18 ÷ 20 Nm
			M16	80 ÷ 85 Nm
	02ZM	A4-70 Stainless steel	M5	3 ÷ 4 Nm
	02ZZ	A2-80 Stainless steel A4-80 Stainless steel	M6	4 ÷ 5 Nm
			M8	10 ÷ 12 Nm
			M10	18 ÷ 20 Nm
03ZZ	A2-70 Stainless steel	M10	18 ÷ 20 Nm	
		M16	80 ÷ 85 Nm	
	01ZU	A4-70 Stainless steel	M12	24 ÷ 26 Nm
			M16	80 ÷ 85 Nm
	02ZE	A4-80 Stainless steel	M8	10 ÷ 12 Nm
	03ZX	A2-70 Stainless steel	M10	18 ÷ 20 Nm
M16			80 ÷ 85 Nm	
	01YN	A2-70 Stainless steel	M5	3 ÷ 4 Nm
			M8	10 ÷ 12 Nm
	01YU	A2-70 Stainless steel	M5	3 ÷ 4 Nm
	02ZZ	A2-80 Stainless steel A4-80 Stainless steel	M6	4 ÷ 5 Nm
			M8	10 ÷ 12 Nm
M10			18 ÷ 20 Nm	
	01YP	A2-70 Stainless steel	M6	4 ÷ 5 Nm
			M8	10 ÷ 12 Nm
	01YX	A2-70 Stainless steel	M4	1 ÷ 4 Nm
	01ZW	A4-70 Stainless steel	M12	24 ÷ 26 Nm
			M16	80 ÷ 85 Nm

TIGHTENING SEQUENCES

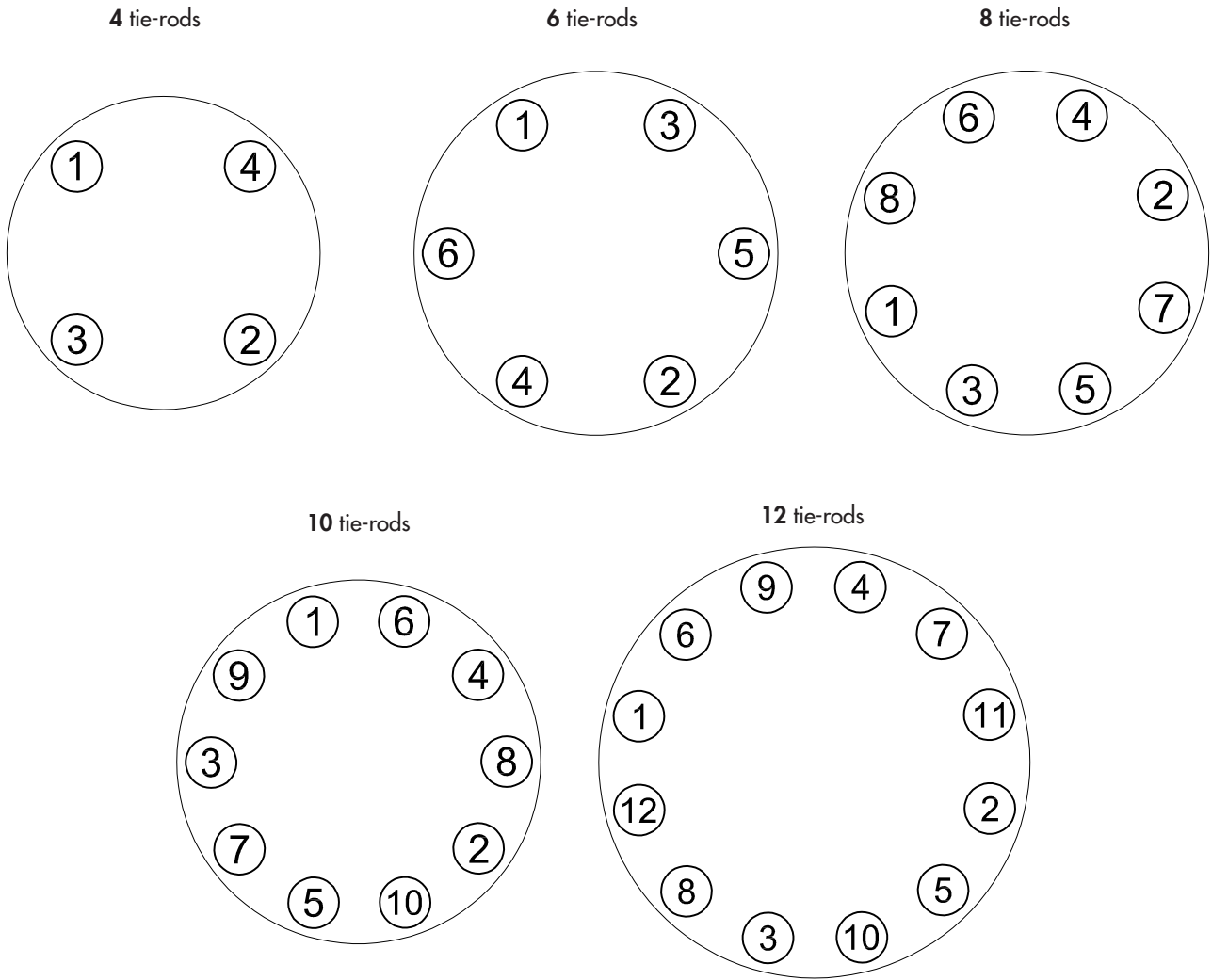

Fig. 15-2

15.3 Lubricants

The AT-HDC actuators are factory lubricated for the life of the actuator in normal working conditions.

→ Refer to the data sheet HDC50100E for lubricant type in relation to the different working temperature ranges.

15.4 Threadlocker

The recommended threadlocker types for AT-HDC the actuators are:

- Loxeal 83•21 or equivalent,
- Loxeal 55•03 or equivalent.



AIR TORQUE

AIR TORQUE S.P.A.

Via dei Livelli di Sopra 11 · 24060 Costa di Mezzate (BG), Italy

Phone: +39 035 682299 · Fax: +39 035 687791

info@airtorque.it · www.airtorque.it